



collect – clean – hold – release

Surface water management with ACO Stormbrixx SD and HD





Surface water management with ACO Stormbrixx

This brochure offers you comprehensive information on all topics of surface water management with focus on the ACO Stormbrixx infiltration system. We use four questions to introduce you to the topic step-by-step and give you valuable practical information and tips on sustainable surface water management in your project or on your property.



Contents

| | |
|--|-----------|
| ACO. The future of drainage. | 4 |
| Surface water management | 7 |
| <hr/> | |
| Four guiding questions in surface water management | 8 |
| <hr/> | |
| How does surface water management and water protection begin? | 10 |
| Surface water drainage | |
| <hr/> | |
| How to achieve the right water quality? | 12 |
| Cleaning systems | |
| <hr/> | |
| How to reduce surface runoff to a natural level? | 14 |
| Application overview – Find the appropriate Stormbrixx construction | 16 |
| Stormbrixx SD and HD | 18 |
| Stormbrixx benefits | |
| Optimised logistics and reduced handling | 21 |
| Stability thanks to brickbonding | 22 |
| Open system for user-friendly inspection and cleaning | 24 |
| Infiltration | 26 |
| Attenuation | 28 |
| Installation | |
| Application examples | 30 |
| Soil cover for installation | 34 |
| System configuration | 36 |
| Side panel and top cover | 40 |
| Connectors | 43 |
| Inspection and maintenance access | 44 |
| Manholes | 46 |
| Pipe connections | 48 |
| Pit excavation and surrounding | 50 |
| Covering over – Infilling | 52 |
| Planning instructions and technical regulations | 53 |
| Maintenance and inspection | 54 |
| Product testing | 57 |
| Legislation and technical regulations | 58 |
| Dimensioning, consultation, development | 59 |
| <hr/> | |
| How to control the discharge rate to the required level? | 60 |
| Flow controls and regulators | 62 |
| Vortex restrictor system | 64 |
| <hr/> | |
| Technical information | 69 |
| <hr/> | |
| ACO materials | 76 |
| The ACO offer for customers | 78 |

ACO. creating the future of drainage

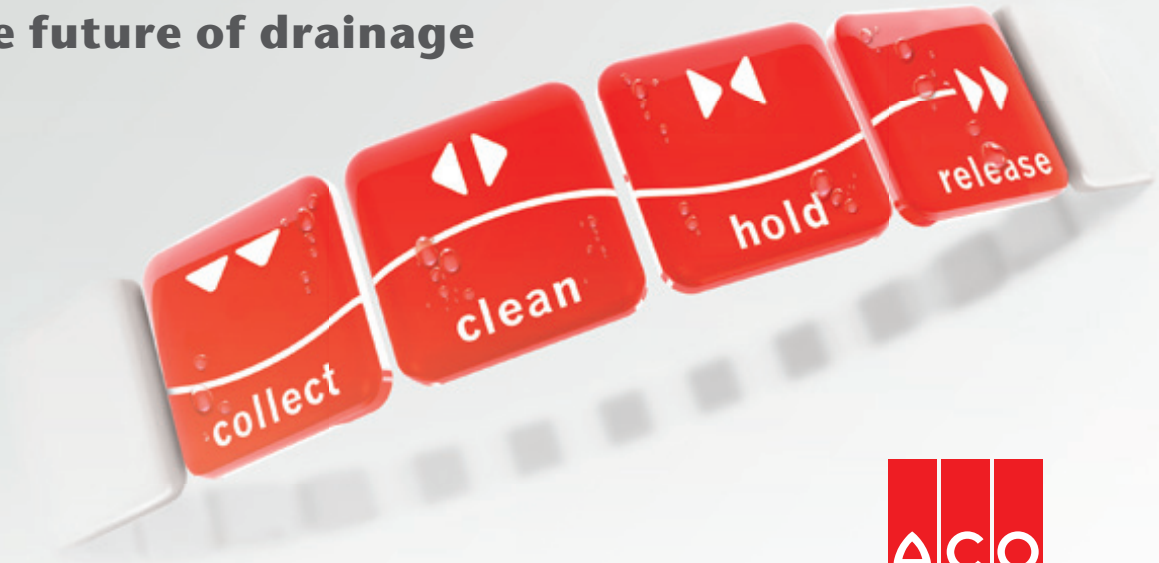

ACO Tiefbau

As a reliable partner of the specialist civil engineering construction materials trade, ACO offers solutions for professional surface water management and water protection. They play a large role in the planning and design of urban, infrastructural and industrial drainage. Whether for public clients, consultant engineers, landscape architects, contractors and

operators, within the ACO Group, ACO Tiefbau not only provides innovative product solutions for civil engineering, road construction and landscape gardening. With comprehensive design tools and services, ACO Tiefbau also assists with the design, construction and sustainable operation of modern drainage systems.

www.aco-tiefbau.de



Headquarters of the ACO Group in Rendsburg/Büdelndorf, Germany



Hans-Julius Ahlmann and his son Iver



ACO Group

The ACO Group is a world market leader in drainage technology. Climate change sets us a challenge to react effectively with innovative solutions to new environmental conditions. With its integrated approach, ACO stands for professional drainage, efficient cleaning, and the controlled discharge or reuse of water. Products include drainage channels and drains, oil and grease separators, backflow stop systems, pumps and pressure-water-tight cellar windows and light shafts.

The family-owned company headquartered in Rendsburg/Büdelndorf, Germany, was founded in 1946 on the site of the Carlshütte foundry – Schleswig-Holstein's first industrial company. It still has very strong roots in the region. The major innovation strength of the ACO Group is built on intense research and development, and its technical expertise in processing polymer concrete, plastic, cast iron, stainless steel and reinforced concrete.

ACO Group at a glance

- 5,000 employees in more than 40 countries (Europe, America, Asia, Australia, Africa)
- 30 production sites in 15 countries
- Sales 2017: Euro 775 million

**ACO. creating
the future of drainage**



ACO Academy for practical training

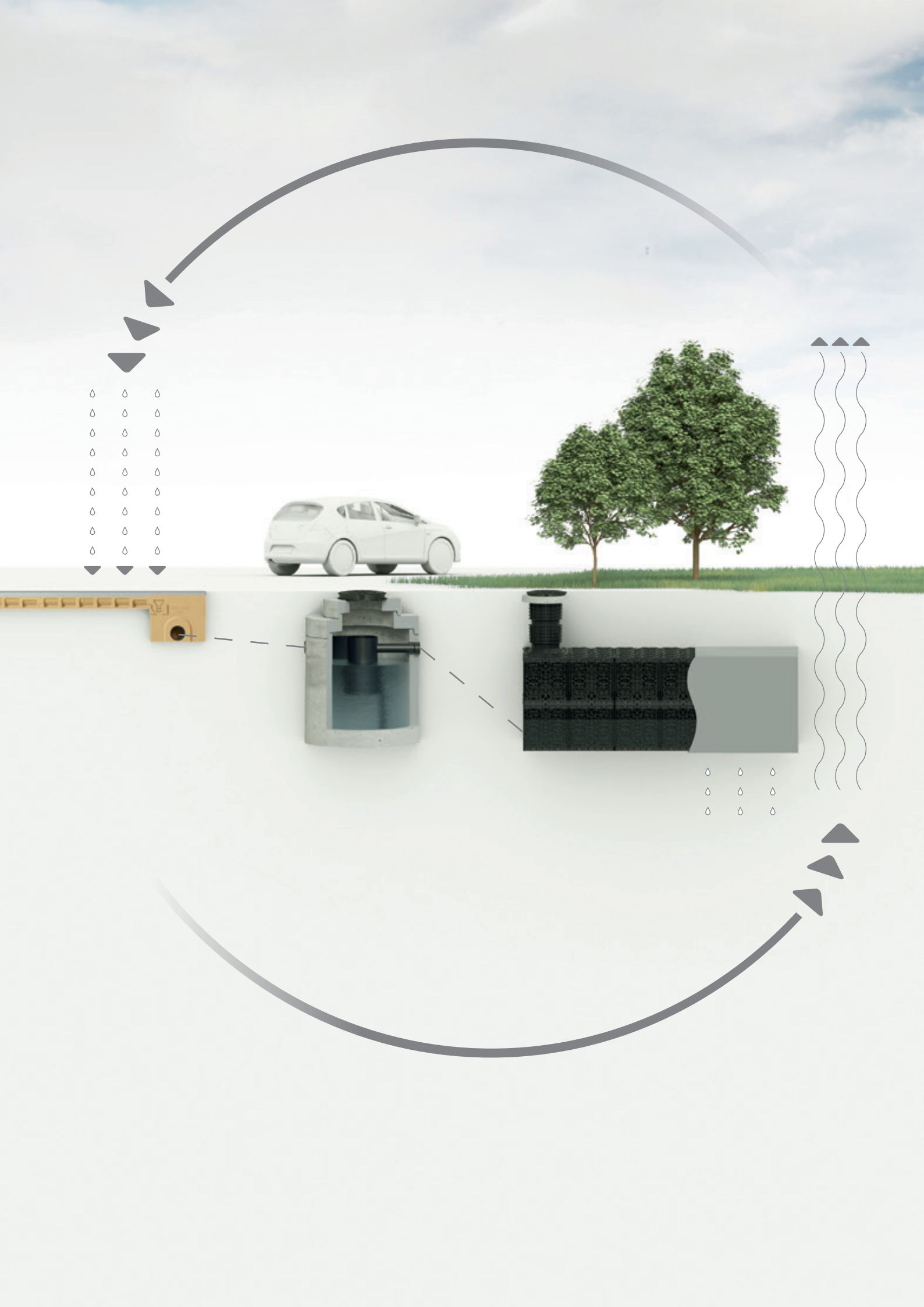

Sustainable surface water management is important for the future

The challenge

Stormwater is an issue that affects us all

For landscape architects, town planners, building architects as well as building owners and operators, rainwater is becoming an increasingly significant challenge to overcome. As well as being a valuable asset that is of vital importance to flora, fauna and people alike, it presents significant sources of risk.

More and more, rainwater is becoming unable to seep away at the points where it falls, and surface sealing is one of the major reasons for this.

The German government has responded to this situation: "The goal of the Federal Government's strategy for sustainable development is to reduce the use of new land for housing and transport to an average of 30 hectares per day by 2030."

Heavy precipitation is another major factor contributing to this trend.

While total precipitation in Germany has only risen slightly year on year, studies have shown that the country has experienced not so much a rise in the intensity, but rather a rise in the number of days on which heavy precipitation occurs.

(Source: G. Malitz, C. Beck, J. Griesner: Veränderung der Starkniederschläge in Deutschland (Changes in heavy precipitation within Germany), from "Warnsignal Klima", 2011, 3rd edition, compiled by WetterWelt GmbH)

The solution

Surface water management – well thought out from collect to release

For every project, ACO offers customized drainage solutions based on the ACO system chain.

■ **Collect and uptake surface water**
Whether line or point drainage, high-quality drainage channels and gullies are available for every application case.

■ **Cleaning and treating surface water:** where does the surface water come from and where should it be discharged? Different sedimentation shafts and systems enable proper treatment of the surface water, as required by law, before it infiltrates the soil or is discharged into the receiving water.

■ **Retaining surface water:** Surface water retention basins are used if the receiving water is overloaded. Products made of concrete and plastic are available, so that the best solution can be chosen for each use. Infiltrations systems, for example, block infiltration drains, also initially retain the surface water. The water is then gradually discharged into the soil, which promotes groundwater recharge.

■ **Discharging surface water:** Controlled discharge of the previously collected surface water is becoming increasingly important. ACO offers suitable flow restriction systems and pumping installations, to discharge the surface water from a collection tank into the receiving water in a controlled way.

Four guiding questions in surface water management

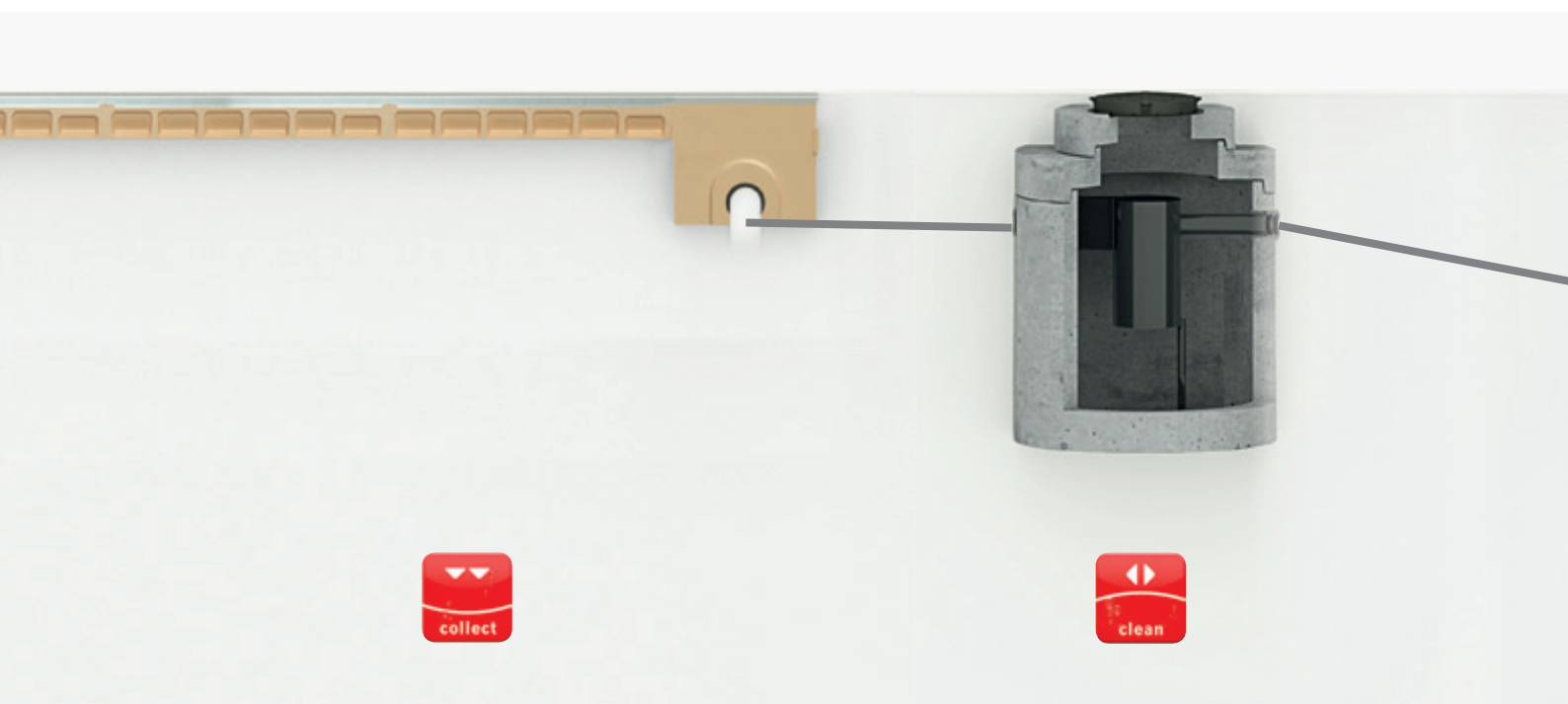

How does surface water management and water protection begin?

ACO surface water drainage

- Drainage channels
- Road and yard drains
- Gully tops
- Manhole covers

from page 10

How to achieve the right water quality?

ACO cleaning systems

- Separators
- Sedimentation and filtration systems

from page 12

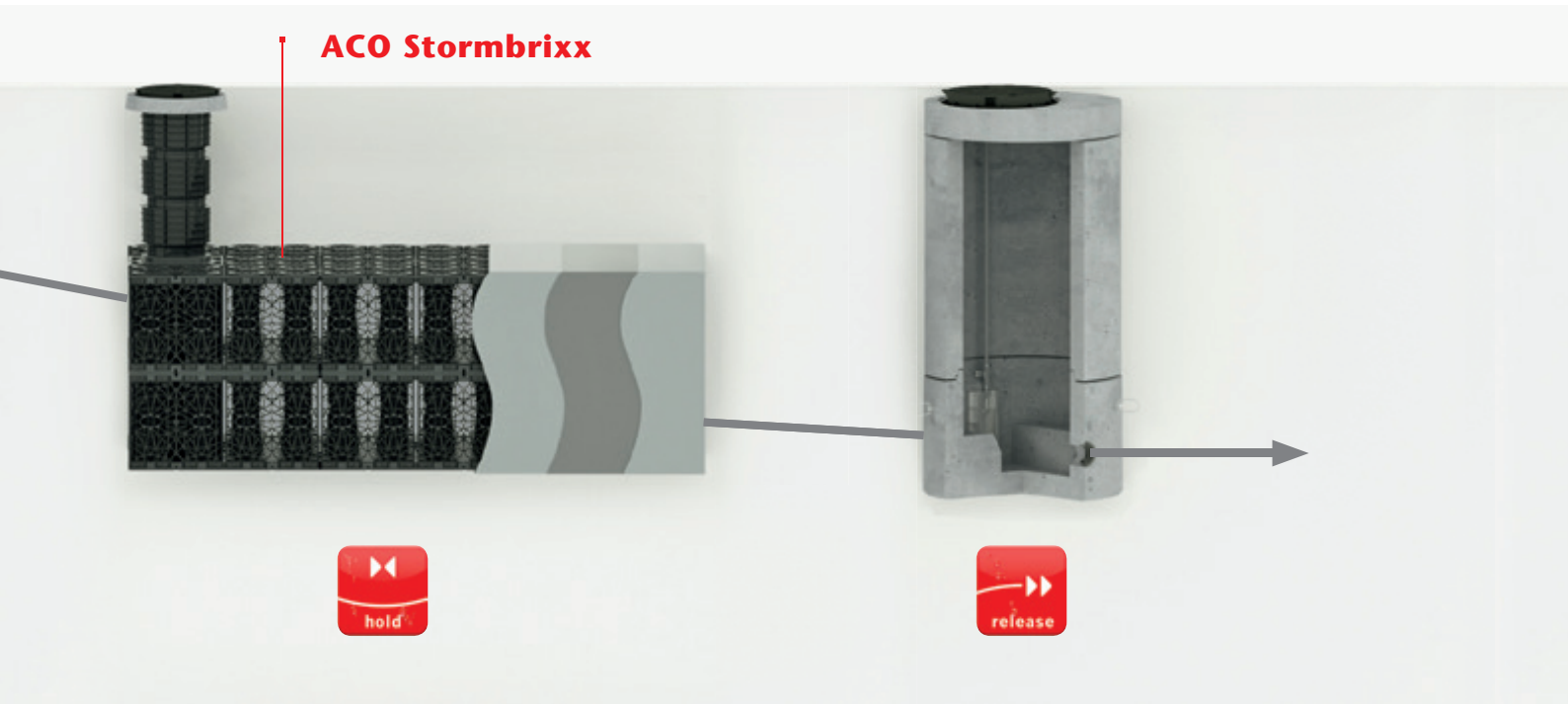
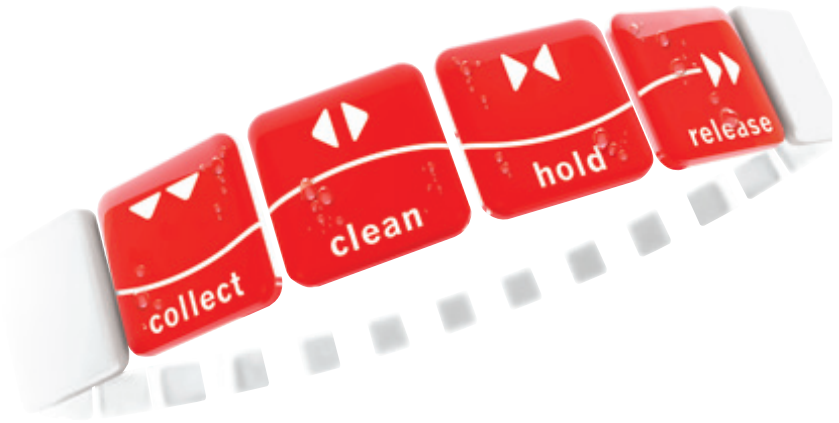

How to reduce surface runoff to a natural level?

ACO infiltration/attenuation systems

- Control valve shafts
- Infiltration and attenuation systems
- Retention basins made of concrete

from page 14

How to control the discharge rate to the required level?

ACO control systems

- Flow control systems
- Pump shafts

from page 60

How does surface water management and water protection begin?

ACO surface water drainage

Reliable and sustainable surface water management begins with reliable collection of the surface water from hard surfaces. ACO offers a comprehensive range of drainage channels and gullies, which have been developed for optimum performance depending on the specific project requirements, to ensure the safety, protection and convenience of people, buildings and traffic routes.

What ACO drainage channels and gullies offer:

- 100 % fulfilment of the relevant standards, e.g. EN 124, EN 1433
- The suitable load case depending on the application case
- Guaranteed safety
- Required hydraulic design depending on the project
- ACO Multiline Seal in and ACO Monoblock RD 200 V (tight) provide a seal between the channel joints as a standard feature
- This means that 100 % of the collected surface water is carried to the destination



ACO DRAIN® PowerDrain

Slim, quiet and extremely efficient



ACO DRAIN® XtraDrain

Demanding linear drainage made easy



ACO DRAIN® Monoblock

Monolithic polymer concrete channel for the highest loads

The ACO PowerDrain is a real all-rounder. The product range impresses with a new nominal width system, universal stability, functionality and freedom of design, innovative noise insulation and a still provides a very good price-performance ratio. With the general building supervisory approval (abZ) No. Z-74.4-78, ACO PowerDrain can be utilised in systems for storing, filling and handling water-polluting liquids (LAU systems).

The extremely lightweight ACO DRAIN® XtraDrain drainage system has been designed for applications up to Class C 250 according to DIN EN 1433. The channel impresses with its simplified handling combined with highest-possible quality levels. Technical details, such as the tried and tested V-profile or the hexagonal structure of the side walls fulfil all requirements for a modern drainage channel. The tongue and groove joint at the start and end of the channel enable a simple and convenient installation.

ACO DRAIN® Monoblock is a drainage system in a monolithic modular design: the channel and cover are manufactured in one casting made from polymer concrete. This thereby creates an extremely stable unit without loose parts, the adhesive joint is also omitted. The unique monocast designed construction guarantees maximum safety and stability for large area drainage from motorways to aircraft operating areas, as well as logistics and industrial areas – making it an ideal alternative to conventional solutions.

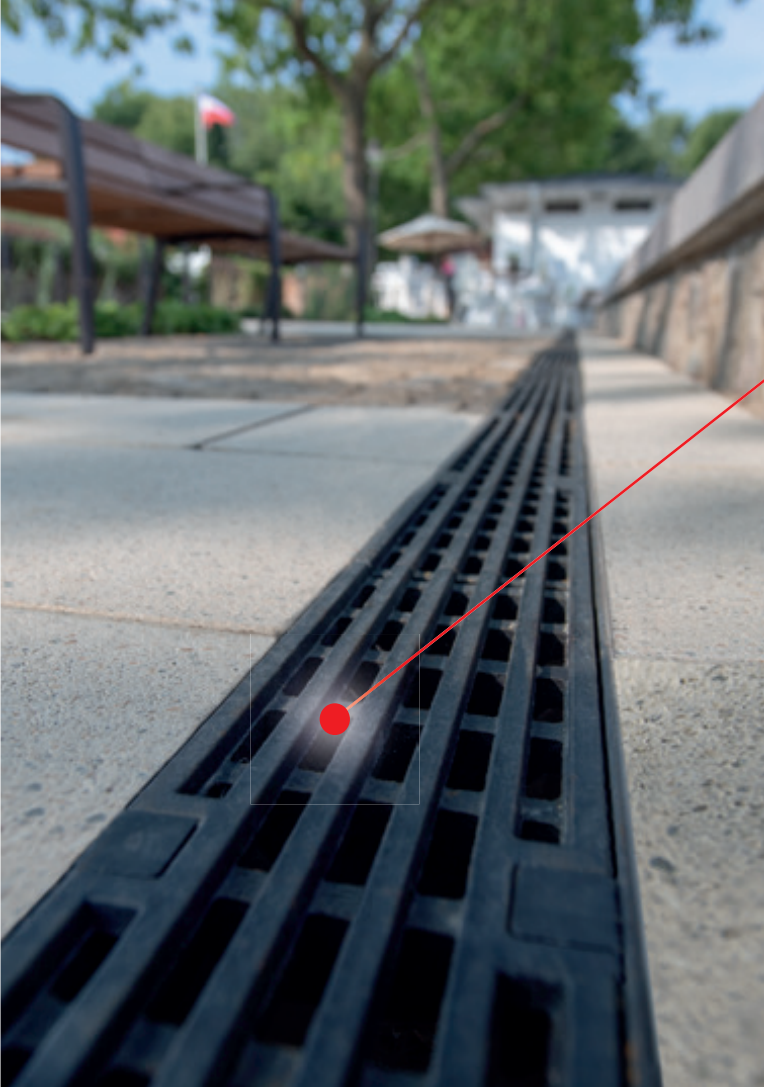

ACO DRAIN® Multiline

Drainage channel with Sealin technologie

An ACO Multiline channel comes with an integrated seal as standard. Using Sealin technology, ACO reliably ensures a water-tight solution for the most important key points in a linear drainage system. This means that ACO Multiline already meets the requirements that will be exacted in the future with respect to water-tightness and water quality. The tightness of ACO DRAIN® Multiline Sealin has been verified and certified by the german IKT (Institut für Unterirdische Infrastruktur, Gelsenkirchen).



ACO Qmax
Retention slot channel with large storage volume

The Qmax drainage system impresses with its small and robust cast attachments. These reduce the contact surfaces in the surface area to a minimum, which therefore makes the system particularly suitable for heavy load areas with high wheel loads up to load class F 900. The Qmax can also be utilised as a retention channel due to the hydraulic performance of the large nominal diameters. High water volumes can therefore be controlled safely and increased rain peak levels can be eliminated.



ACO Yard Drain
Water brought to the point

The ACO DRAIN® Yard Drain with Pointlock provides, with a load class up to B 125, a point shaped drainage system for outdoor areas. This system is easy to install and fulfils the highest requirements in terms of workmanship and appearance. The Pointlock screwless stop, locking mechanism makes the cover vandal-proof and theft-proof. The cover is excellently suited for applications in school yards, railway platforms and for other areas with heavy public traffic.



ACO Combipoint PP
Lightweight road gully made of plastic

The ACO Combipoint PP made of polypropylene now enables plastic road gullies to be utilised for the first time, and which can be aligned as rotated, telescoped, shortened as well as inclined. The drain-off modules only weigh 2.5 to 2.8 kg, which results in an essential benefit for installation and handling. The logic is hereby based on a modular principle of concrete parts according to DIN 4052. The system is complemented with corresponding cast attachments for Classes C 250 and D 400.

How to achieve the right water quality?

ACO cleaning systems

Collected surface water from traffic areas, car parks and uncoated metal roofs or façades contains substances that must not be discharged directly into the receiving water (outfall) or the groundwater. If they are discharged into nature, they constitute a risk to soil, groundwater and the environment. The collected surface water must therefore be treated, to prevent sediments, tyre wear particles and heavy metals from getting into the sewers or nature.

Different sedimentation and surface water treatment plants are available, depending on the degree of contamination of the collected surface water.

What ACO cleaning systems offer:

- Hydraulic calculation to DWA-M 153
- Load class depending on application case
- Required dimensioning by object



ACO Combipoint SSA

Separation road gully

Application areas

- Roads, paths, open areas

Operating principle

- Hydro-dynamic sedimentation

Pollution and contamination degree

- Less load

Surface dimensions

- Smaller surfaces
- Permeability value 0.6 for DWA-M 153 (according to expert assessment from IKT)



ACO Sedised-P

Sedimentation system

Application areas

- Pre-cleaning for heavily polluted surfaces
- Complete cleaning for slightly polluted surfaces up to 3,000 m² according to DWA-M 153 Case D 25 a

Operating principle

- Sedimentation

Pollution and contamination degree

- Moderate to heavy load

Surface dimensions

- Small to medium-sized surfaces (depending on the degree of pollution)



ACO Sedised-C

Sedimentation system

Application areas

- Pre-cleaning for heavily polluted surfaces
- Complete cleaning for slightly polluted surfaces up to 19,000 m² according to DWA-M 153 Case D 25 a

Operating principle

- Sedimentation

Pollution and contamination degree

- Moderate to heavy load

Surface dimensions

- Small to large surfaces (depending on the degree of pollution)

In individual cases, it may make sense to utilise a light liquid separator in accordance with DIN EN 858 in connection with rainwater infiltration or retention. Rain water can e.g. be polluted when it leaks out of solid or paved over surfaces. In principle, rain water which could be mixed with mineral origins in specific applications for light fluids, must be provided with a treatment via suitable separation systems and or retention facilities must be provided.

The treated rain water must subsequently be routed into the waste water sewer (DIN 1999-100).

ACO can provide various coalescence separators. A selection can be made between:

- Reinforced concrete containers
- Polymer concrete containers
- Coalescence separator with filter
- Filter-free multiple drain technology



ACO Oleopator Pro

Polymer concrete
light liquid separator



NEW



ACO Sedismart-C

Sedimentation system

Application areas

- Pre-cleaning for heavily polluted surfaces
- Complete cleaning for slightly polluted surfaces up to 23,000 m² according to DWA-M 153 Case D 25 a

Operating principle

- Hydro-dynamic sedimentation

Pollution and contamination degree

- Moderate to heavy load

Surface dimensions

- Medium-sized to large surfaces (depending on the degree of pollution)

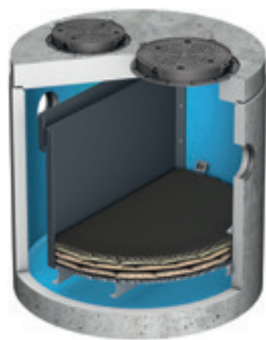

ACO HMS heavy metal separator

Safe solution for metal roofs

Application areas

- Surfaces loaded with hydrocarbons (traffic)
- Surfaces loaded with heavy metal (metal roofs)

Operating principle

- Sedimentation, adsorption and absorption

Pollution and contamination degree

- Slight to very heavy load

Surface dimensions

- Up to 10,000 m²

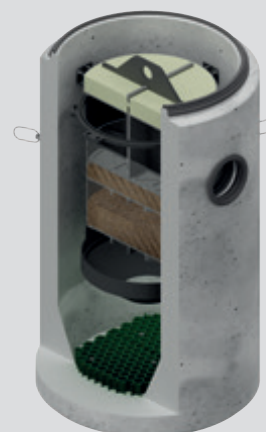

ACO Hydrosed active

Hydrodynamic separator

Application areas

- Surfaces loaded with hydrocarbons (traffic)
- Surfaces loaded with heavy metal (metal roofs)
- Cleaning away surface water from traffic areas

Operating principle

- Hydro-dynamic sedimentation
- Adsorption and absorption (active by means of ACO substrate filter)

Pollution and contamination degree

- Very heavy load

Surface dimensions

- Small to medium-sized surfaces

How to reduce surface runoff to a natural level?

ACO infiltration/attenuation systems

Groundwater recharge and the retention and controlled discharge of stormwater into the receiving water are two central topics of surface water management. Classically, retention basins or storage channels are used here. The ACO Stormbrixx block infiltration system provides an additional innovative and optimal solution:

In infiltration the previously collected and treated surface water is collected in the ACO Stormbrixx system. From there it is gradually discharged into the soil and promotes groundwater recharge. Encased in a waterproofing geomembrane, a type of tank is formed, where the previously collected and cleaned surface water is stored in. With a time delay the water will be discharged (e.g. by a throttle) into the receiving water. The controlled discharge of surface water into sewers or the receiving water is becoming increasingly important, especially in case of heavy rainfall events. In this way, the peak runoff of the surface water of a storm is spread over a longer period and is therefore reduced.

What the ACO Stormbrixx block infiltration system provides:

- Safe and reliably system stability through structural calculations
- Optimised logistics and easy handling
- Simple inspection and cleaning
- Hydraulic design to DWA-A 138
- ACO Stormbrixx SD has been tested by MFPA Leipzig GmbH
- ACO Stormbrixx HD is DIBt certified



ACO Stormbrixx SD
Modular (SUDS) infiltration system for car traffic

ACO Stormbrixx SD is utilised as an infiltration system underneath driveways, access roads, public areas or also in private areas. It can be used for infiltration and attenuation. The system stores the previously collected rainwater and releases it with a time delay into the ground, the receiving water or sewage system.



ACO Stormbrixx HD
Modular (SUDS) infiltration system for occasional heavy traffic use

ACO Stormbrixx HD is an infiltration system which can be utilised underneath driveways, access roads, public areas or heavy traffic load areas which are not driven on too frequently. The ACO Stormbrixx HD system can be used for infiltration and attenuation.

RStO 12

German guideline for the standardization of pavement structures of traffic areas. Please aware different and individual guidelines in every country.

The RStO 12 (guidelines for the standardization of the superstructure of traffic areas) must be observed when utilising the Stormbrixx system.

Load classes according to RStO 12, Paragraph 2.5.1 must be particularly considered.

The design-dimension relevant factor is the number of expected 10-t axle transitions up to the end of the anticipated period of use (30 years).

Always adhere to the product-specific conditions of use.

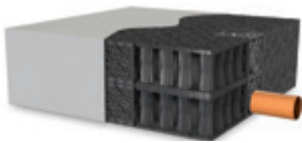

ACO Stormbrixx
as surface water infiltration

ACO Stormbrixx with a geotextile encapsulation for intermediate storage capacity and subsequent infiltration of rainwater.

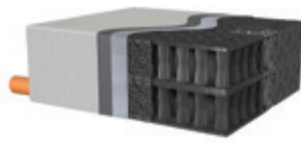

ACO Stormbrixx
as surface water retention

ACO Stormbrixx with a geotextile encapsulation and sealing membrane for retention and subsequent, controlled discharge of rainwater.

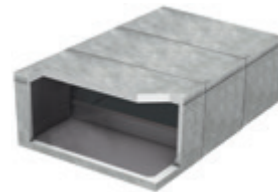

ACO Retention basin
made of concrete

For retention of rainwater to protect public sewer networks against overloading caused by large volumes of rainwater.

Application overview – Find the appropriate Stormbrixx construction

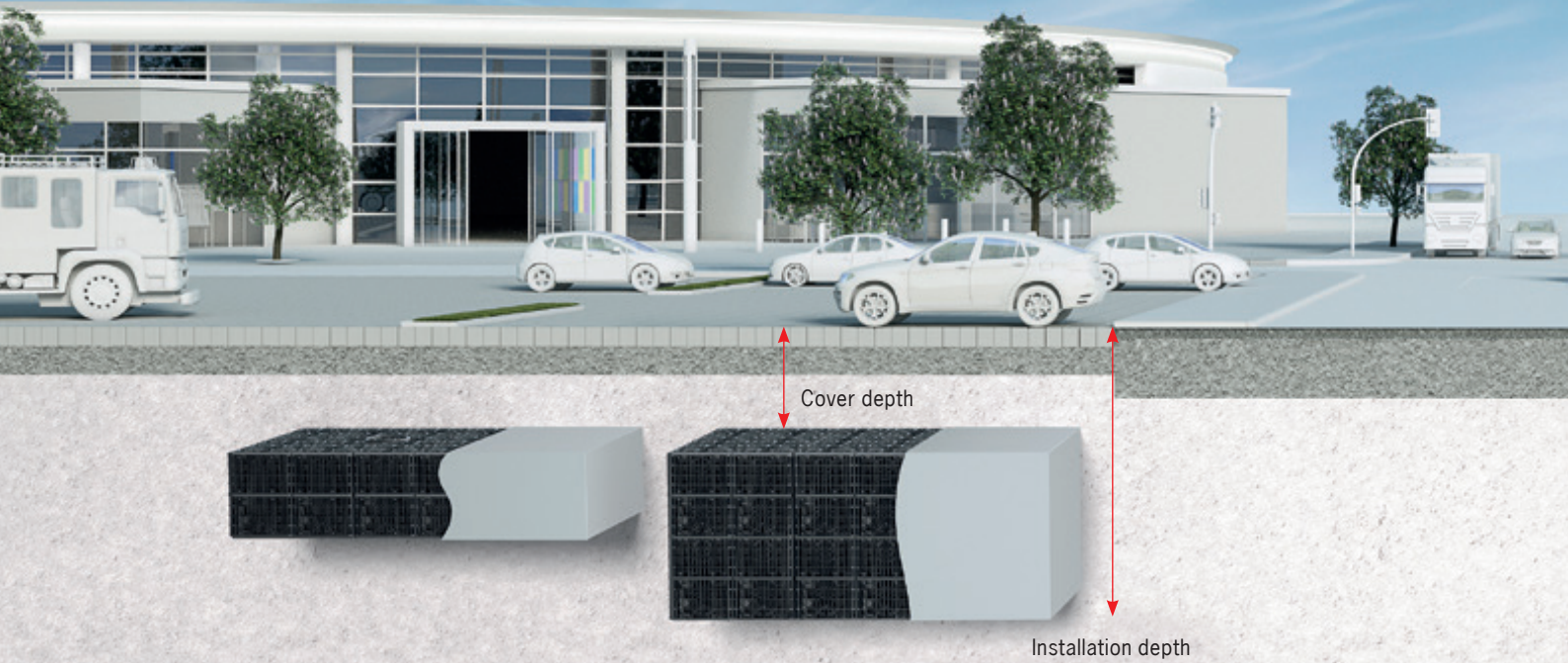

NEW Stormbrixx SD

Standard Duty: Suitable for car traffic and occasionally moving emergency services

Application category

frost-free installation depth, at least 80 cm deep (DIN 1054), without groundwater influence:

- Landscaped areas, no vehicles
- Landscaped areas, driven by mowers
- Pedestrian areas, protected by obstacles (bord, bollards) from driving
- Driveways to carparks, crossing of emergency vehicles possible
- Carparks, crossing of emergency vehicles possible
- Access roads for residential property with scheduled crossings by special vehicles (refuse or tank vehicles) as well as operating service vehicles

| Layers | Walkable | | | Trafficable | | |
|--------------|--|--------------|---------------------------------|--------------|------|---------------------------------|
| | Cover depth | | Installation depth maximal [mm] | Cover depth | | Installation depth maximal [mm] |
| minimal [mm] | maximal [mm] | minimal [mm] | | maximal [mm] | | |
| 1 | 800 | 2000 | 2914 | 800* | 2000 | 2914 |
| 2 | 800 | 2000 | 3828 | 800* | 2000 | 3828 |
| 3 | Please contact ACO Application engineering in your country | | | | | |

*Please consider the required road construction

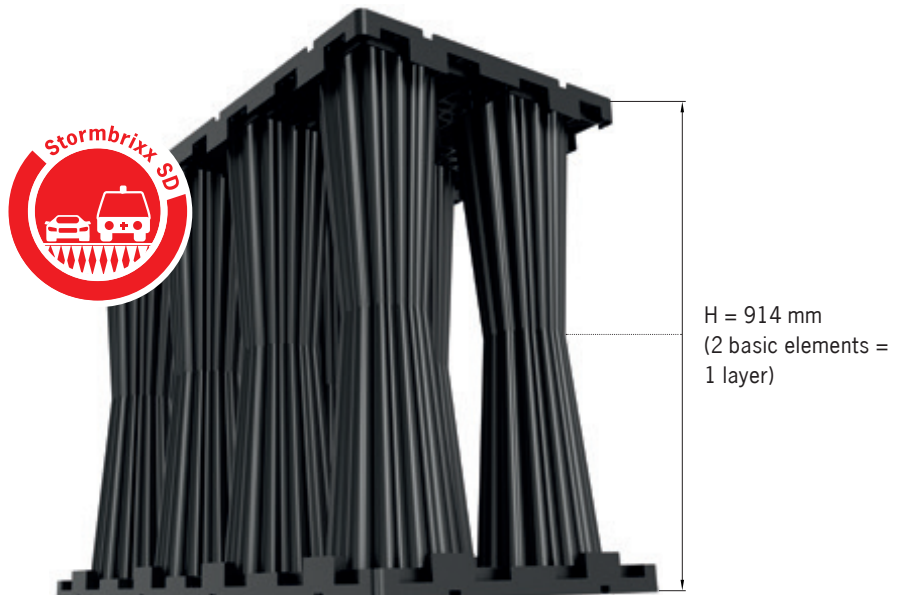

Service

ACO Application engineering advises you. Please contact them in your country.

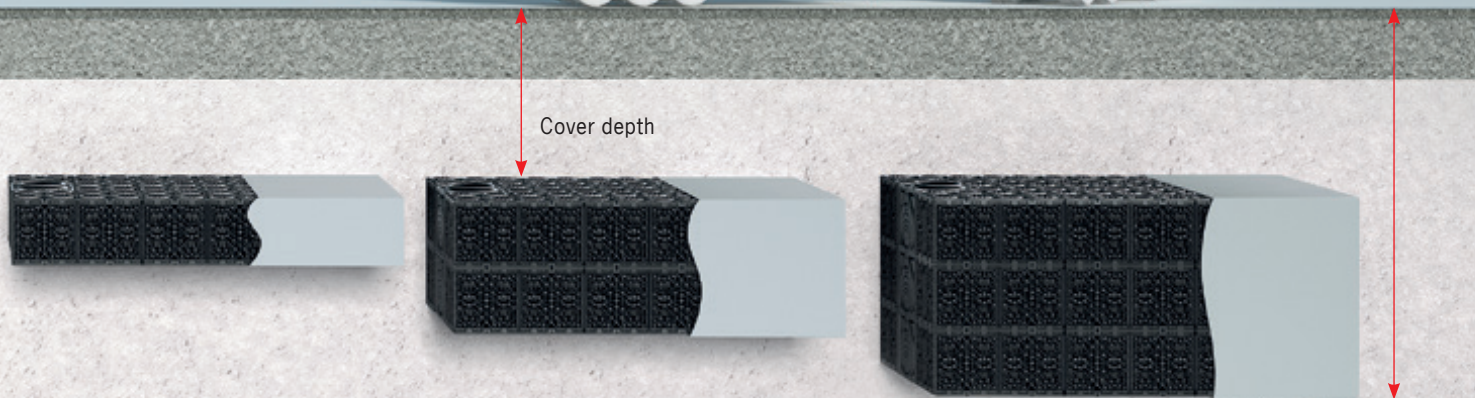
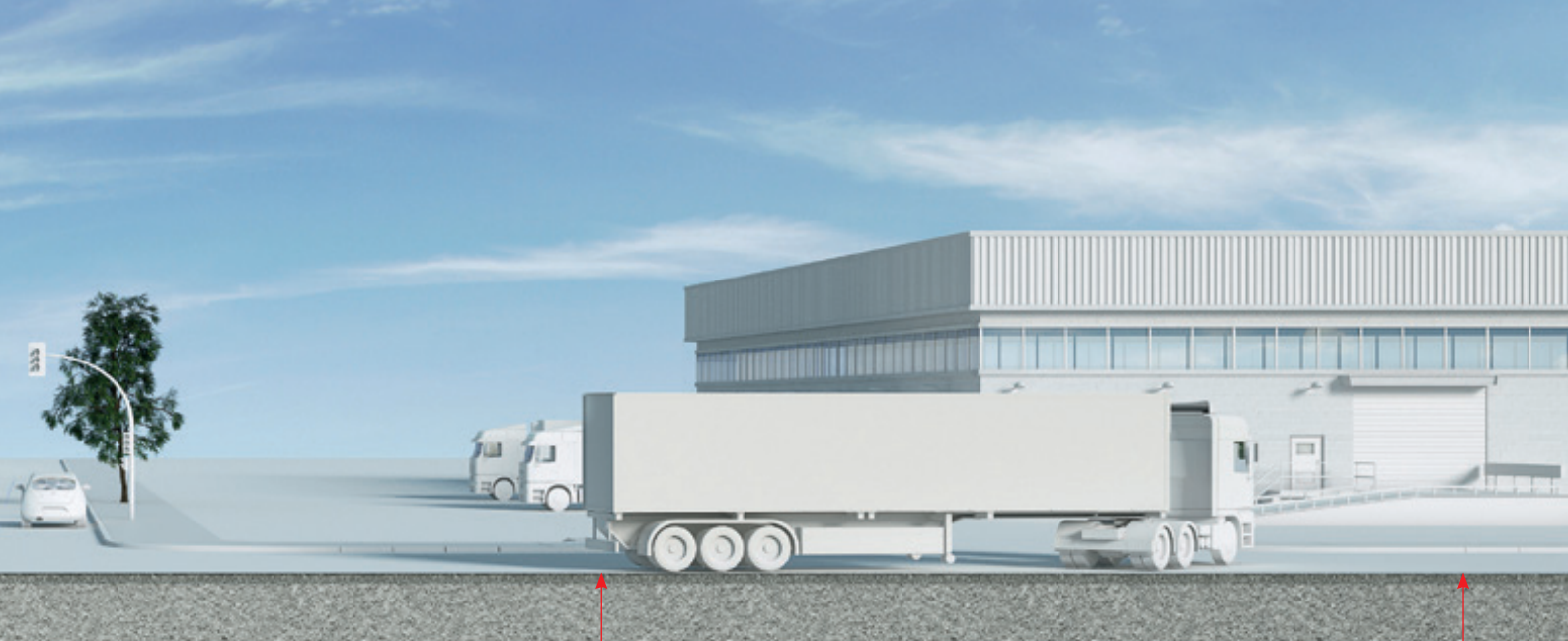

Stormbrixx HD

Heavy Duty: Suitable for occasional heavy traffic use

Application category

frost-free installation depth,
without groundwater influence:

- Landscaped areas, no vehicles
- Landscaped areas, driven by mowers
- pedestrian areas, protected by obstacles (bord, bollards) from driving
- driveways to carparks, crossing of emergency vehicles possible
- carparks, crossing of emergency vehicles possible
- Access roads for residential property with scheduled crossings by special vehicles (refuse or tank vehicles) as well as operating service vehicles
- Storage areas and secondary facilities of traffic routes which are not constantly used by heavy traffic (mainly stationary traffic, no traffic lane. Connection between storage areas)
- Traffic routes with heavy traffic: only in consultation with ACO Application engineering

| Layers | Walkable and trafficable | | | Trafficable with heavy traffic | | |
|--------|--|--------------|---------------------------------|--------------------------------|--------------|---------------------------------|
| | minimal [mm] | maximal [mm] | Installation depth maximal [mm] | minimal [mm] | maximal [mm] | Installation depth maximal [mm] |
| 1 | 800* | 3400 | 4010 | 1000 | 3400 | 4010 |
| 2 | 800* | 3400 | 4620 | 1000 | 3400 | 4620 |
| 3 | 800* | 3400 | 5230 | 1000 | 3400 | 5230 |
| 4 | Please contact ACO Application engineering in your country | | | | | |

*Please consider the required road construction



H = 610 mm
(2 basic elements = 1 layer)

ACO Stormbrixx SD

Standard duty



ACO Stormbrixx SD was tested in 2017 by the Gesellschaft für Materialforschung und Prüfungsanstalt für das Bauwesen Leipzig mbH (MFPA Leipzig).

NEW

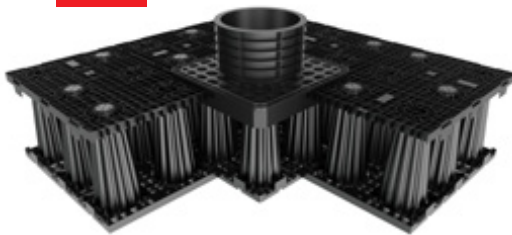

New cover plate enables ACO Stormbrixx SD in half layer

Special features

- Height of 1 layer: 914 mm
- Basic elements/m³: 3
- Volume/basic element: 319 l
- Storage coefficient: 97 %
- Min. cover depth: 0.8 m
- Max. cover depth: 2.0 m
- Tested by MFPA Leipzig (Installation up to 2 layers)

Example: 10 m³ = 10,000 l/319 = 32 basic elements

General features

FEEL SAFE WITH US

50 YEARS



Recyclable polypropylene material provides a robust and corrosion-resistant basis for a long-lasting infiltration system. The basic elements form a loadable structure.

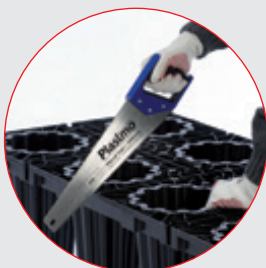

Basic elements can be cut in half to allow integration into the overall system.



Functional design combined with an intelligent snap-lock system make for problem-free handling and rapid installation.

ACO Stormbrixx HD

Heavy duty



ACO Stormbrixx HD was awarded the general official approval Z-42.1-500 by the German Institute for Building Technology (DIBt) as an additional level of certainty.

Special features

- Height of 1 layer: 610 mm
- Basic elements/m³: 4.5
- Volume/basic element: 209 l
- Storage coefficient: 95 %
- Min. cover depth: 1.0 m
- Max. cover depth: 3.40 m
- DIBt certified (Installation up to 3 layers)

Example: 10 m³ = 10,000 l/209 = 48 basic elements

Basic elements are laid and connected together in pattern in order to create structural rigidity in the overall system.

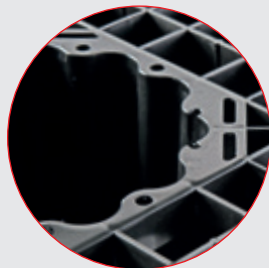

The pillars are also filled with storm water. Small openings at the base of the pillars optimise water treatment in the product.

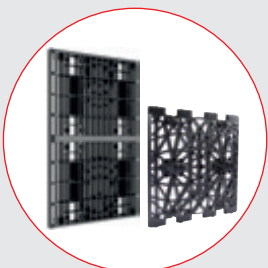

Side panel perimeters for the entire system offer a sound base for laying the geotextile wrapper.



Thanks to the open structure of ACO Stormbrixx, inspection cameras and cleaning devices can have free passage through the system.

Practical Stackable



Double pallet with basic ACQ Stormbrixx elements



Stormbrixx benefit 1

Optimised logistics and reduced handling

Both the basic elements and the side panels, as well as the covers for the ACO Stormbrixx infiltration system stack perfectly for ease of transport. The building blocks fit into each other precisely, thus reducing the volume to be transported compared to traditional systems, resulting in substantially lower transport costs and CO₂ emissions.

ACO Stormbrixx makes it possible to transport required product units on a truck.

- Stormbrixx SD: 347 m³ storage capacity
- Stormbrixx HD: 309 m³ storage capacity

For conventional infiltration systems, up to four vehicles would be needed. Stacking the basic Stormbrixx elements therefore reduces transport costs.



Optimised transport



The modular ACO Stormbrixx infiltration system reduces transport costs and therefore more than halves CO₂ consumption and the storage space required in storerooms and on the construction site compared to other systems



Short paths to the pallets increase the installation speed

Stormbrixx benefit 2

Stability thanks to brickbonding

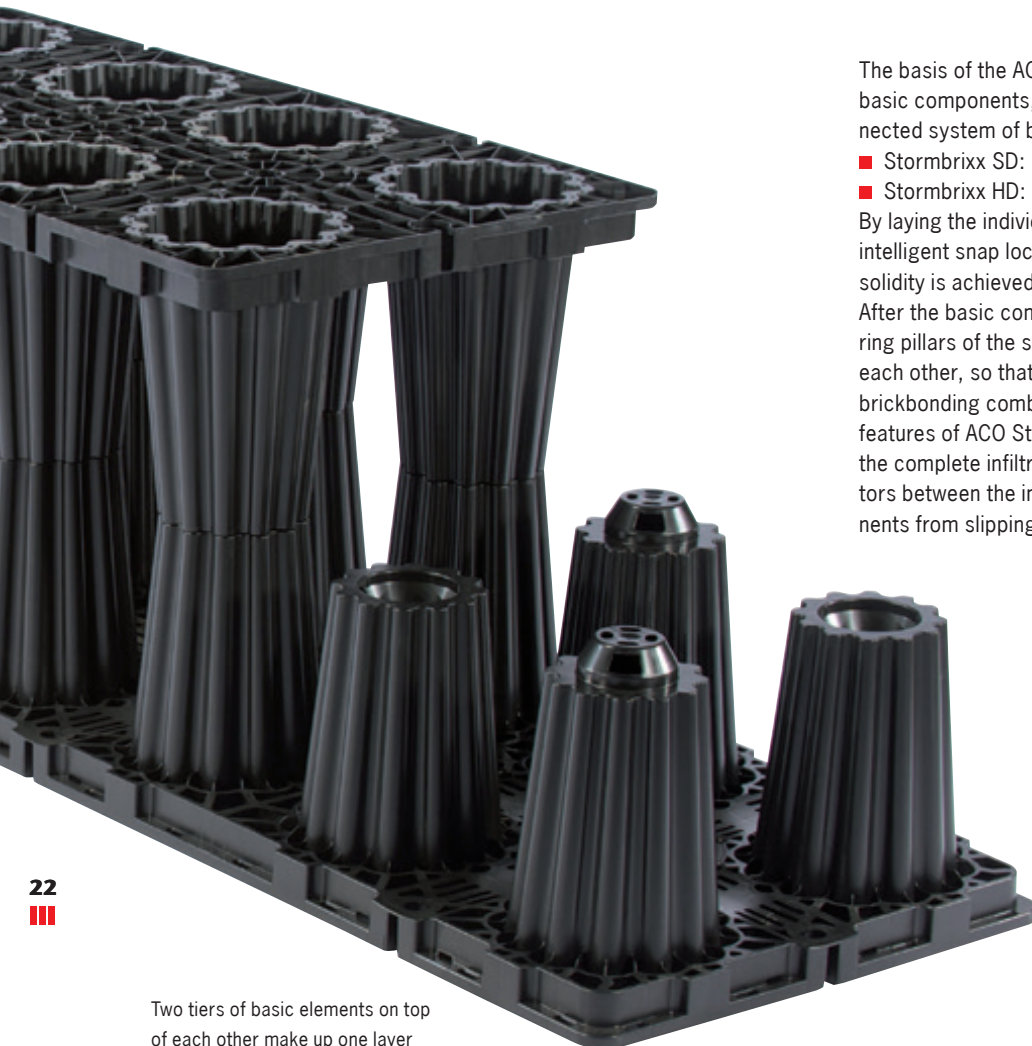

The basis of the ACO Stormbrixx system is provided by the basic components, which are combined on site into an interconnected system of blocks.

■ Stormbrixx SD: 1200 x 600 x 457 mm

■ Stormbrixx HD: 1205 x 602 x 305 mm

By laying the individual components in patterns and using an intelligent snap lock system, an exceptional level of structural solidity is achieved for the overall system.

After the basic components have been assembled, the load-bearing pillars of the system are precisely vertically aligned above each other, so that loads are distributed downwards evenly. The brickbonding combination of the components is one of the key features of ACO Stormbrixx. It provides a stable construction for the complete infiltration system. All that is required are connectors between the individual layers to prevent the basic components from slipping.

Two tiers of basic elements on top of each other make up one layer

Robust

**High
integral
strength**



Male and female connectors audibly lock into place during assembly

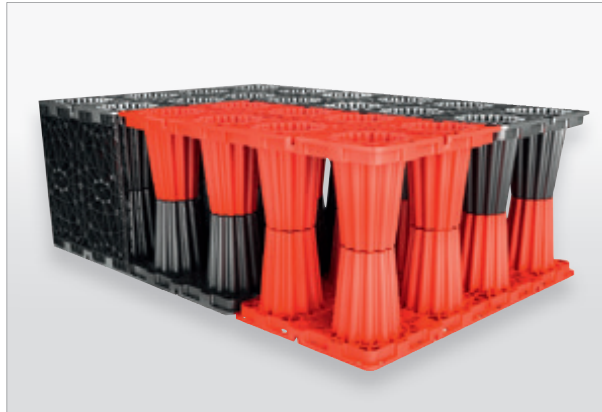

The basic elements are installed in interlocking patterns to ensure the stability of the entire infiltration system in addition

Modular

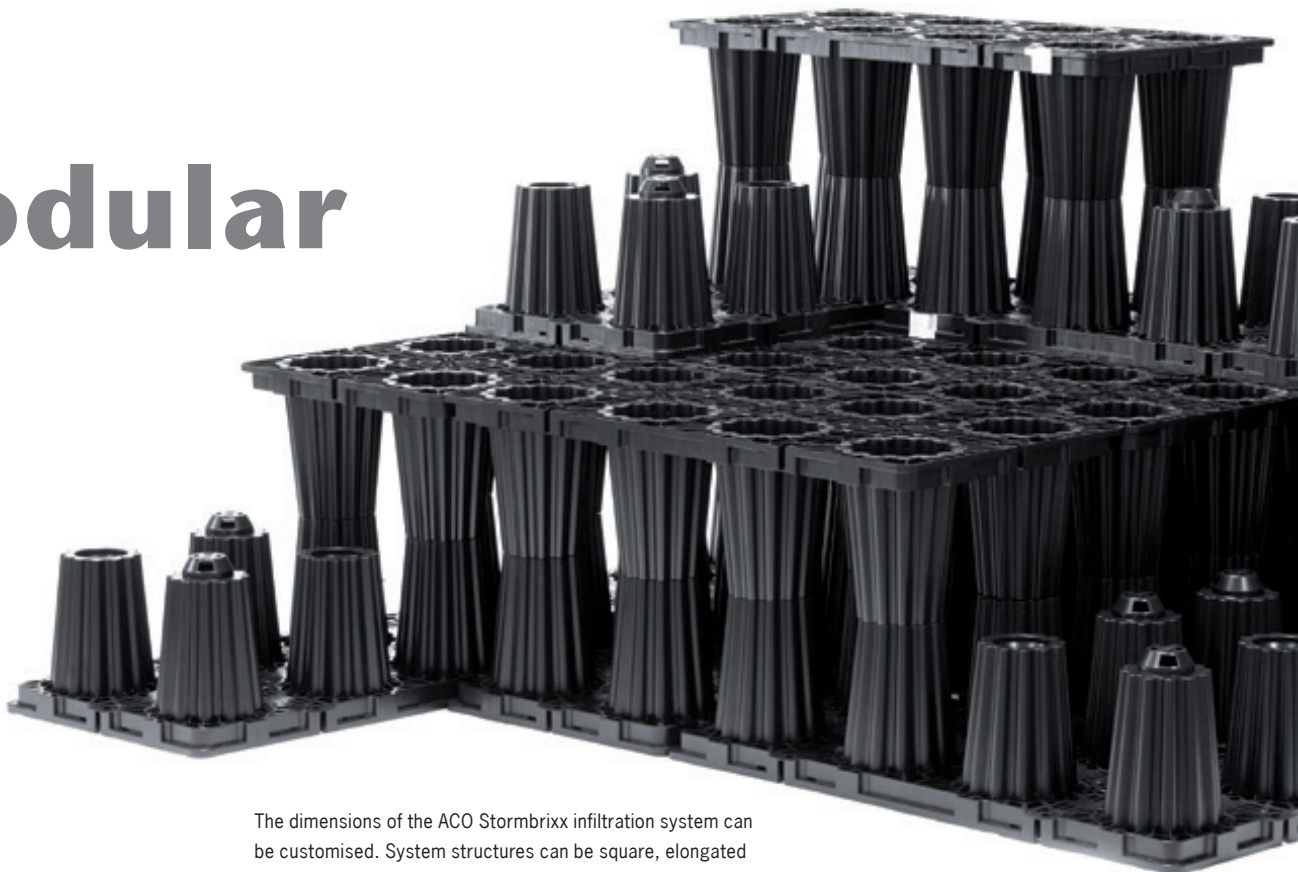

The dimensions of the ACO Stormbrixx infiltration system can be customised. System structures can be square, elongated or even as a 90° variant.

Stormbrixx benefit 3

Open system for user-friendly inspection and cleaning

Inspection cameras or sewer flushing nozzles pass through the shaft openings into the ACO Stormbrixx block infiltration system. The inspection camera or flushing nozzle is inserted vertically into the infiltration system. The special design of the ACO Stormbrixx enables camera inspection and flushing in all directions: Optimum maintenance and inspection of the system is possible, not only in the longitudinal direction, but also in the transverse direction. The open structure of ACO Stormbrixx significantly reduces the number of access shafts compared to other infiltration systems. The ACO Stormbrixx infiltration system is accessed via the LW 400 shaft cover. This opening also enables simultaneous flushing and extraction of the soiled water.

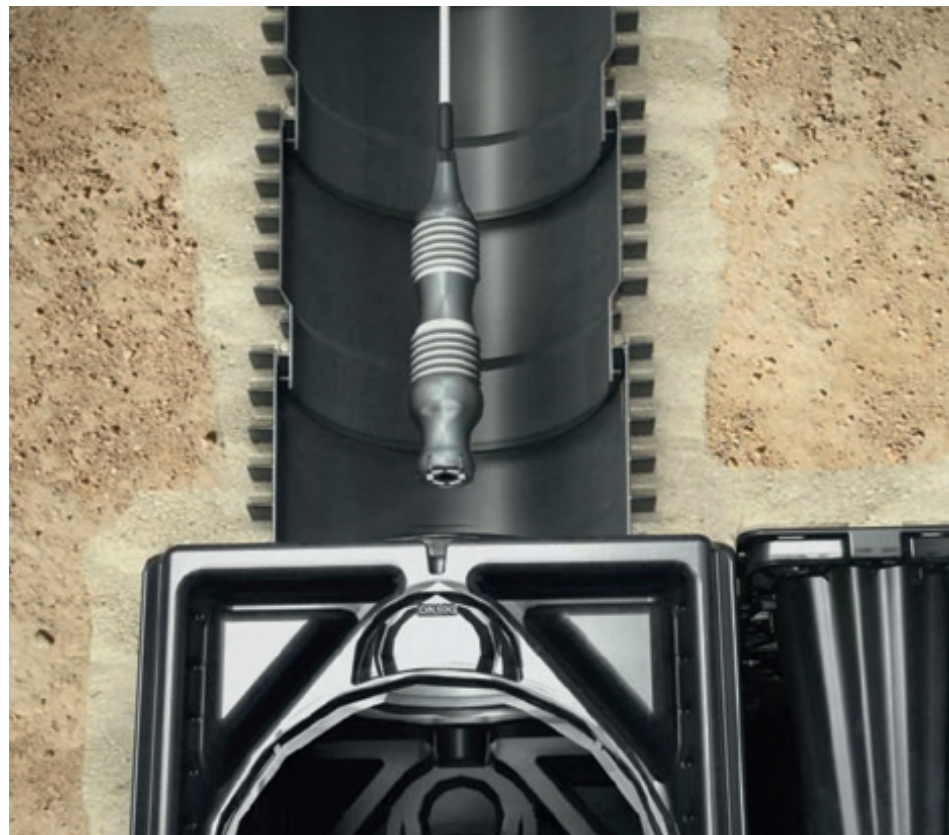

The inspection camera is introduced vertically into the infiltration system via ACO Stormbrixx upper parts and intermediate/bottom shaft sections

Fully inspectable and accessible

Infiltration/attenuation system

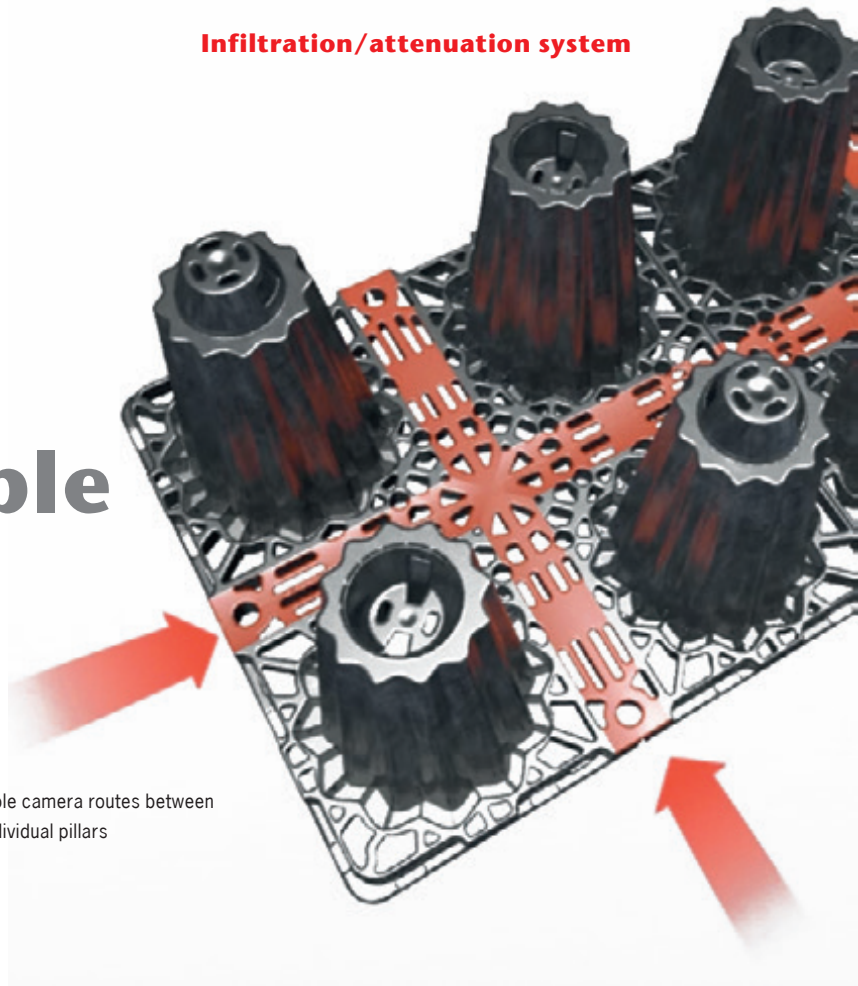

Possible camera routes between the individual pillars

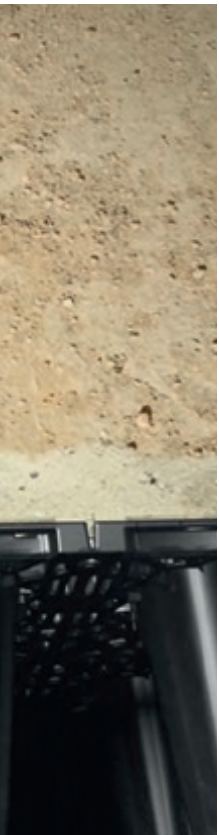

Slide inspection cameras can be easily used in the ACO Stormbrixx system



Cleaning equipment with a rinsing head. Any deposits that may be in the system can be pressure-rinsed and suctioned at the same time.

Effective replenishment of groundwater – infiltration of storm water

As a SUDS infiltration system, the ACO Stormbrixx offers a dual effect ecological solution: treated surface water is collected underground in the block infiltration system. It thus stores the surface water initially in case of heavy rainfall. The water then gradually seeps into the soil and in doing so helps to recharge the groundwater.

The legal basis for infiltration is provided by the state water law, the DWA (Associa-

tion for Water, Wastewater and Waste) standard A 138 “Planning, Construction and Operation of Facilities for the infiltration of Storm Water”, and the DWA advisory leaflet M 153 “Recommended Actions for Dealing with Storm Water”.

The subsoil must be capable of infiltration water and there must not be an underground impermeable layer.

No harmful substances may penetrate the ground or the groundwater via infiltration.

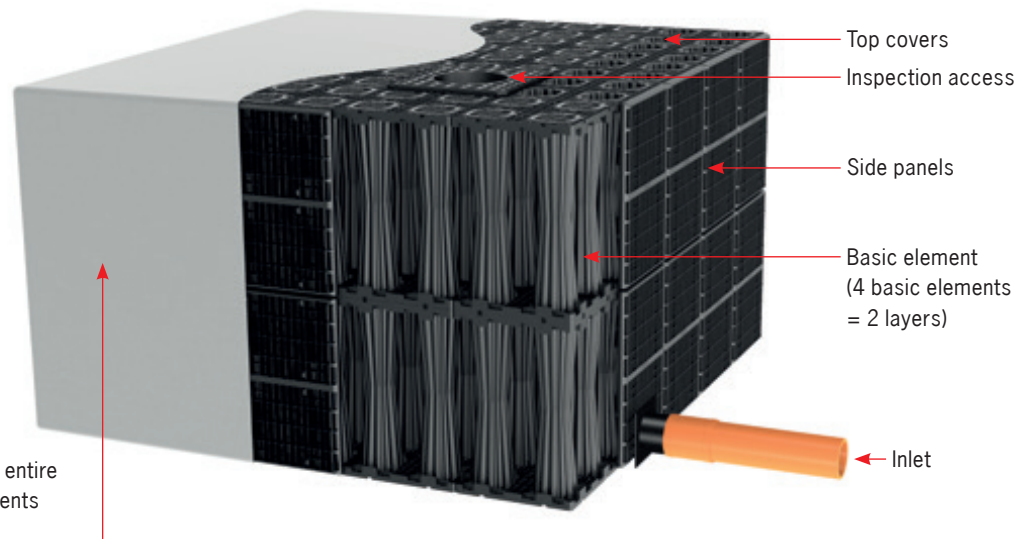

Geotextile as protective layer for the entire infiltration system prevents soil penetration

Geotextile robustness class: GRC 3
Weight: 200 g/m²
Thickness: 1.9 mm

Infiltration



The system is constructed of basic elements that are laid in interlocking patterns

Infiltration/attenuation system



ACO Application Technology creates a corresponding installation plan for every building project.
Reference project: Heider Marktpassage, Heide: ACO Stormbrixx HD as an infiltration system underneath car parking areas.



The protective geotextile is then laid around the infiltration system so that it is completely covered



Filling the infiltration system

Inlet from ACO Sedised-C via a KG pipe with ACO adapter for pipe connection in the infiltration system

Controlled release – attenuation of storm water

As a bulk store below driveways, public areas or on private grounds, the ACO Stormbrixx infiltration system stores the previously collected rainwater and releases it in a time-delayed fashion into the watercourse or sewage system. The drainage channels are thereby relieved during heavy rainfall. Each application must consider the respective soil and traffic loads.

ACO Stormbrixx has a restricted application in areas where groundwater is present. Separate calculations must be carried out on a case-by-case basis.

Attenuation

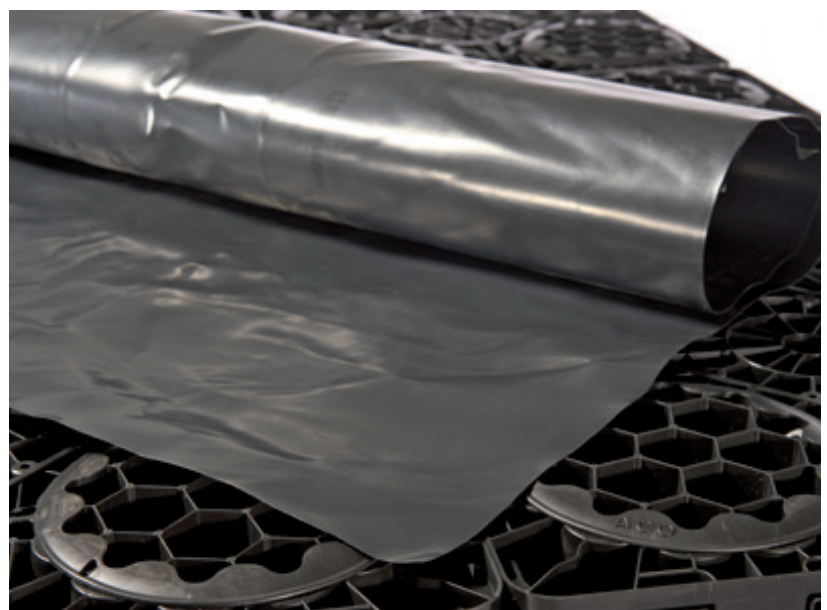
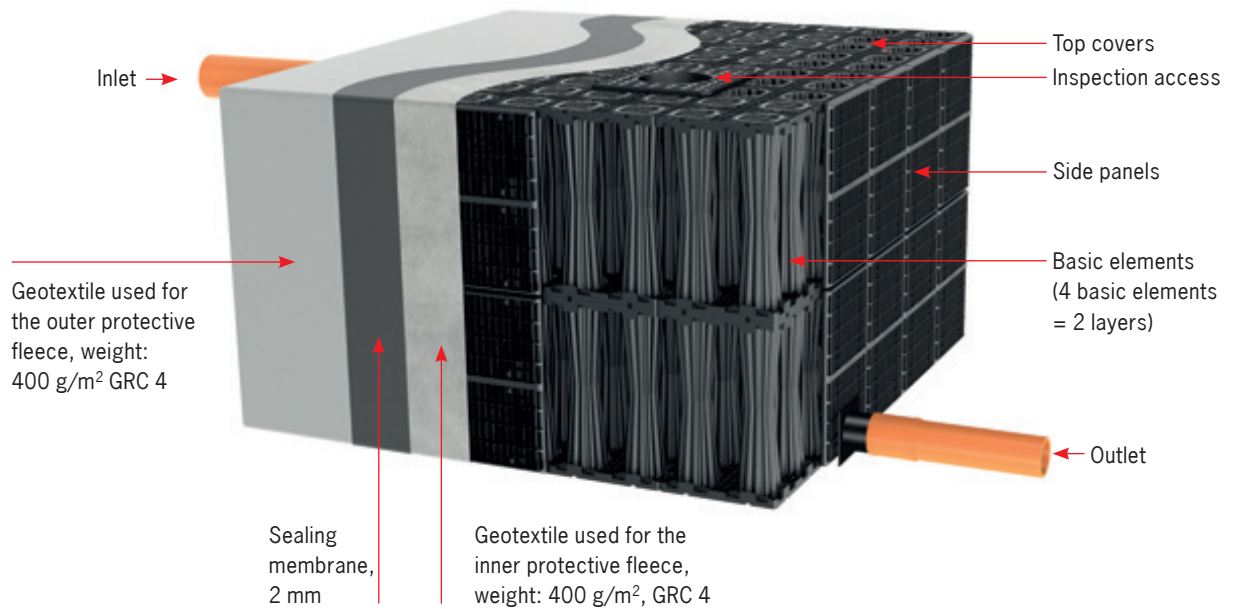

Sealing membrane

Infiltration/attenuation system

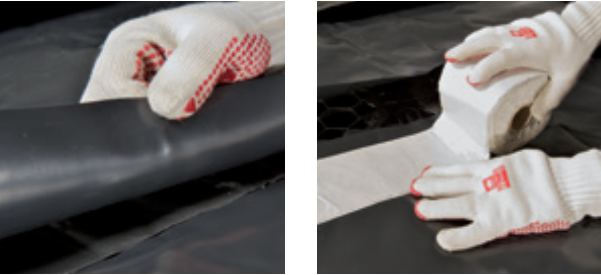

The bulk storage system is wrapped with an inner protective fleece and a sealing membrane



The sealing membrane is then welded

Reference Albert-Schweitzer-Gemeinschaftsschule school, Schwentimental:
 The surface water of the small multifunctional pitch, the sand (volleyball) court and the track for school, club and leisure sports within the school's grounds is collected via ACO channels and is stored temporarily and retained in the ACO Stormbrixx block infiltration system, from where it is then discharged into the outfall after a time delay through controlled discharge by means of a flow restriction element.



The outer protective fleece is applied once the sealing membrane is complete

Application examples – Infiltration

Public areas, roads and parking areas

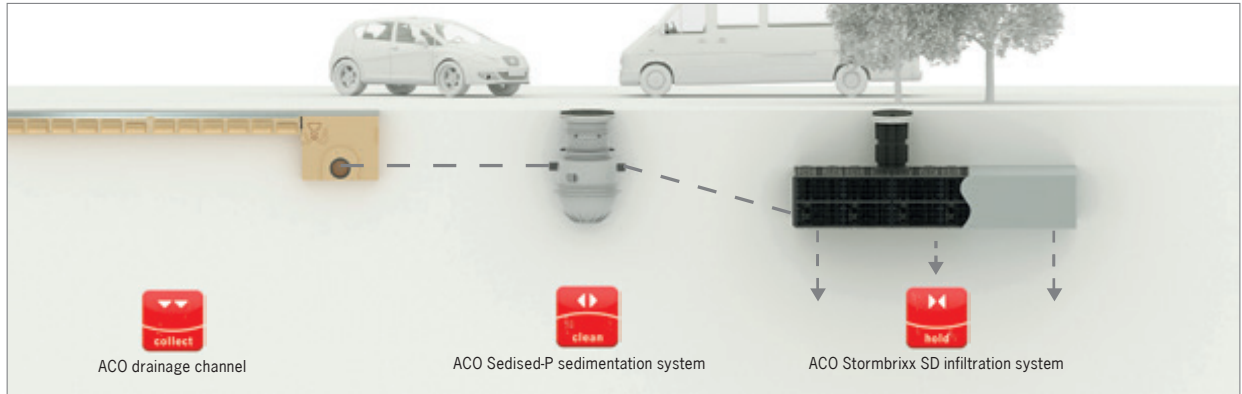

Application example of ACO system chain for rainwater infiltration with ACO Stormbrixx

Logistics space



Application example of ACO system chain for rainwater infiltration with ACO Stormbrixx

Infiltration – Metal roof

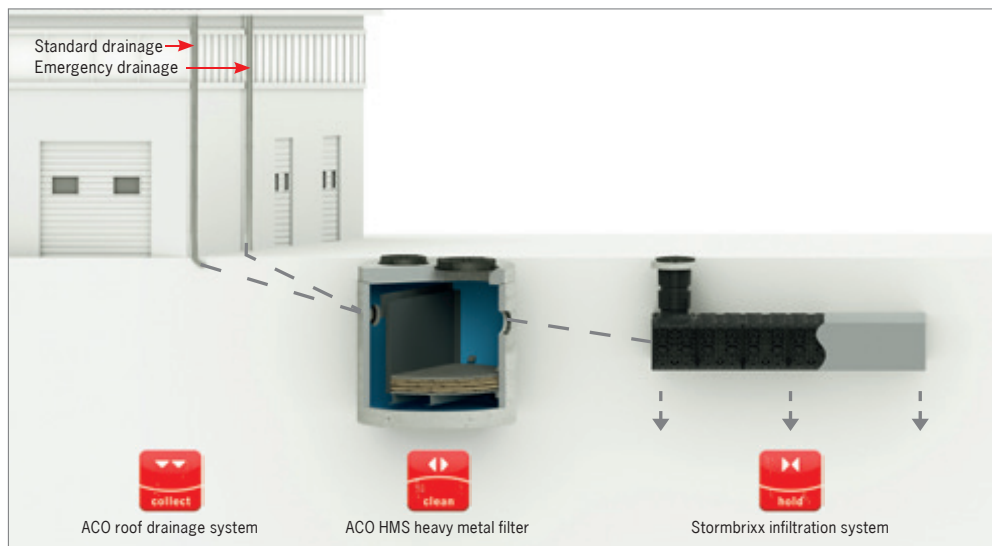

Standard drainage

Intake of rainwater through ACO flat roof gullies and ACO GM-X pipes – roof water cleaned using ACO HMS heavy metal filter – temporary storage and time-delayed infiltration of the rainwater through the ACO Stormbrixx infiltration system..

Emergency drainage

The emergency drainage for roof surfaces as defined in DIN 1986 Section 100, Paragraph 5.3.1, Edition 2008, does not exclude direct drainage via a treatment stage (ACO HMS heavy metal filter) into the ACO Stormbrixx infiltration system. The infiltration system and the heavy metal filter must be dimensioned accordingly.

Application example of ACO system chain for rainwater infiltration with ACO Stormbrixx

Application examples – Attenuation

Public areas, roads and parking areas

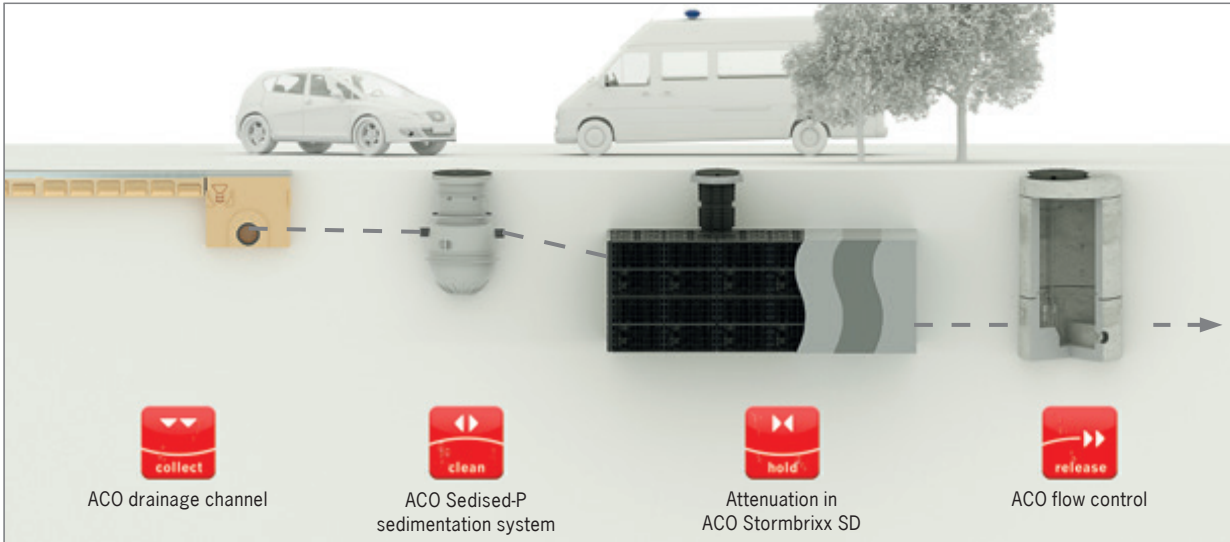

Application example of ACO system chain for rainwater attenuation with ACO Stormbrixx

Reservoir for fire extinguishing water

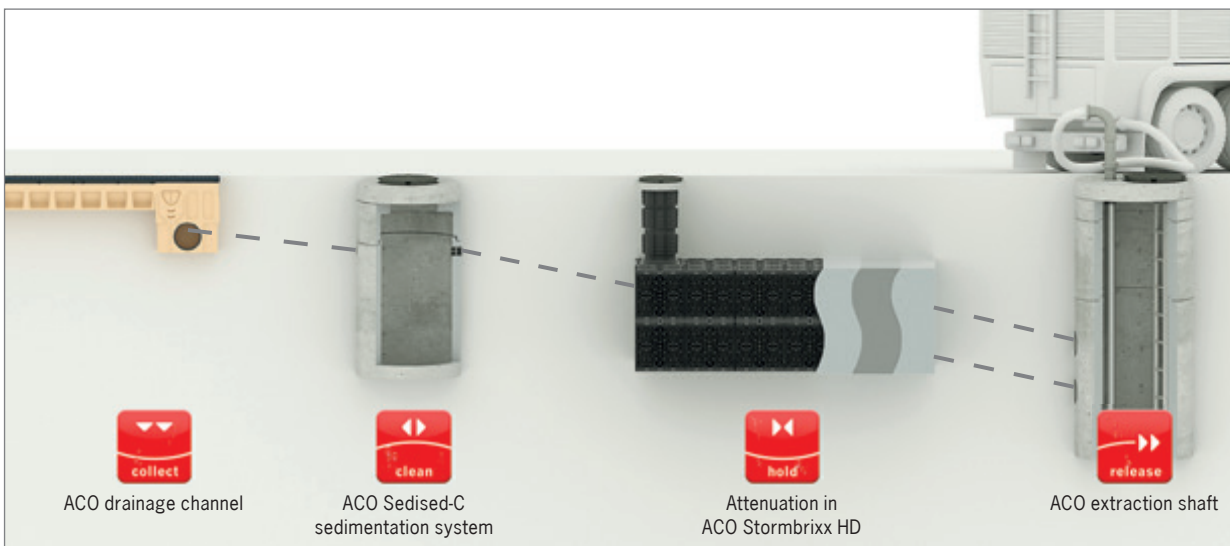

Application example of ACO system chain as a fire extinguishing water tank according to DIN 14230. Fire extinguishing water tank and extraction shafts must be approved and accepted by the responsible authority.

Service

ACO Application engineering advises you. Please contact them in your country.

Application example: Drainage of Car parks

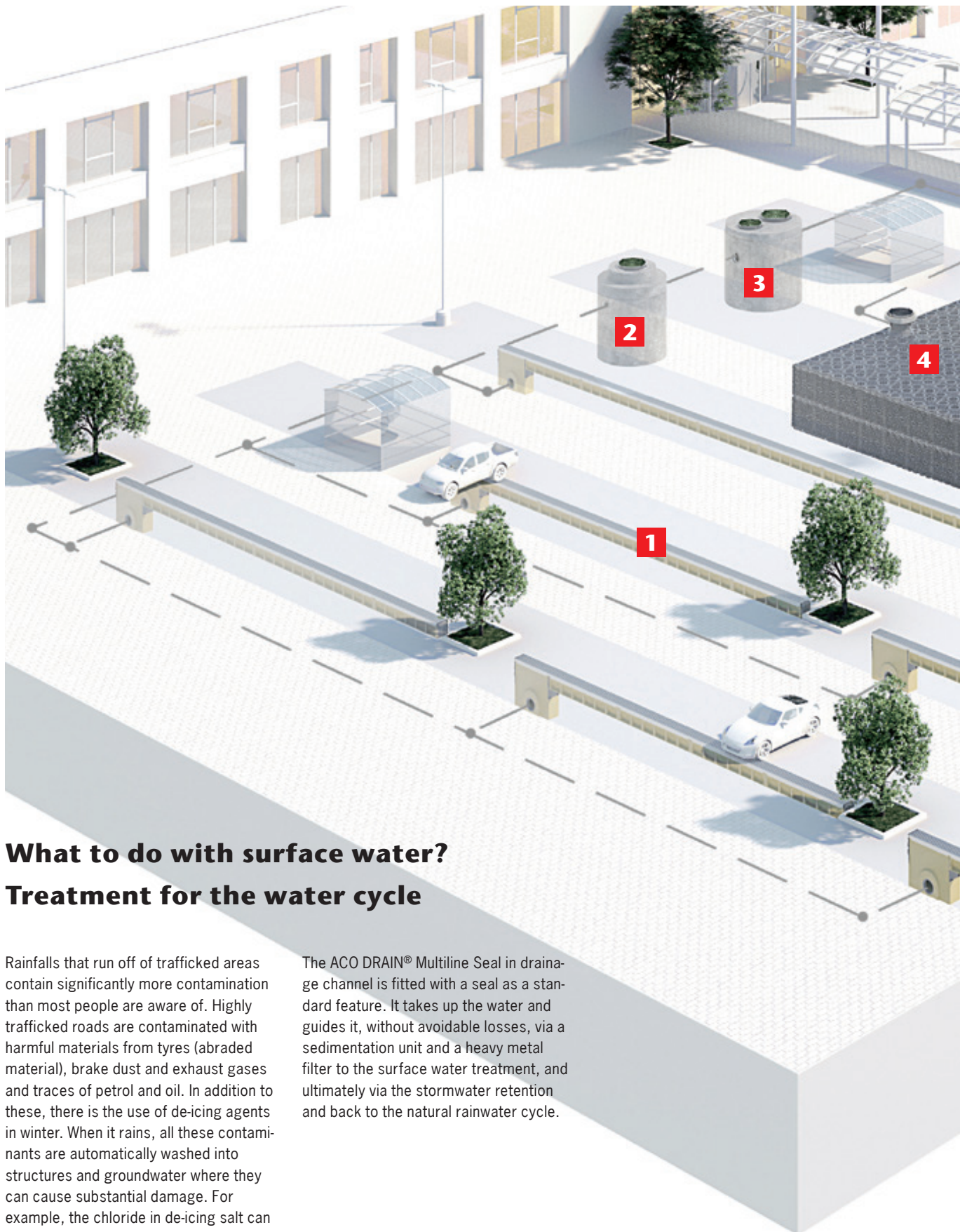

What to do with surface water? Treatment for the water cycle

Rainfalls that run off of trafficked areas contain significantly more contamination than most people are aware of. Highly trafficked roads are contaminated with harmful materials from tyres (abraded material), brake dust and exhaust gases and traces of petrol and oil. In addition to these, there is the use of de-icing agents in winter. When it rains, all these contaminants are automatically washed into structures and groundwater where they can cause substantial damage. For example, the chloride in de-icing salt can cause corrosion and weakening of the foundation.

The ACO DRAIN® Multiline Seal in drainage channel is fitted with a seal as a standard feature. It takes up the water and guides it, without avoidable losses, via a sedimentation unit and a heavy metal filter to the surface water treatment, and ultimately via the stormwater retention and back to the natural rainwater cycle.

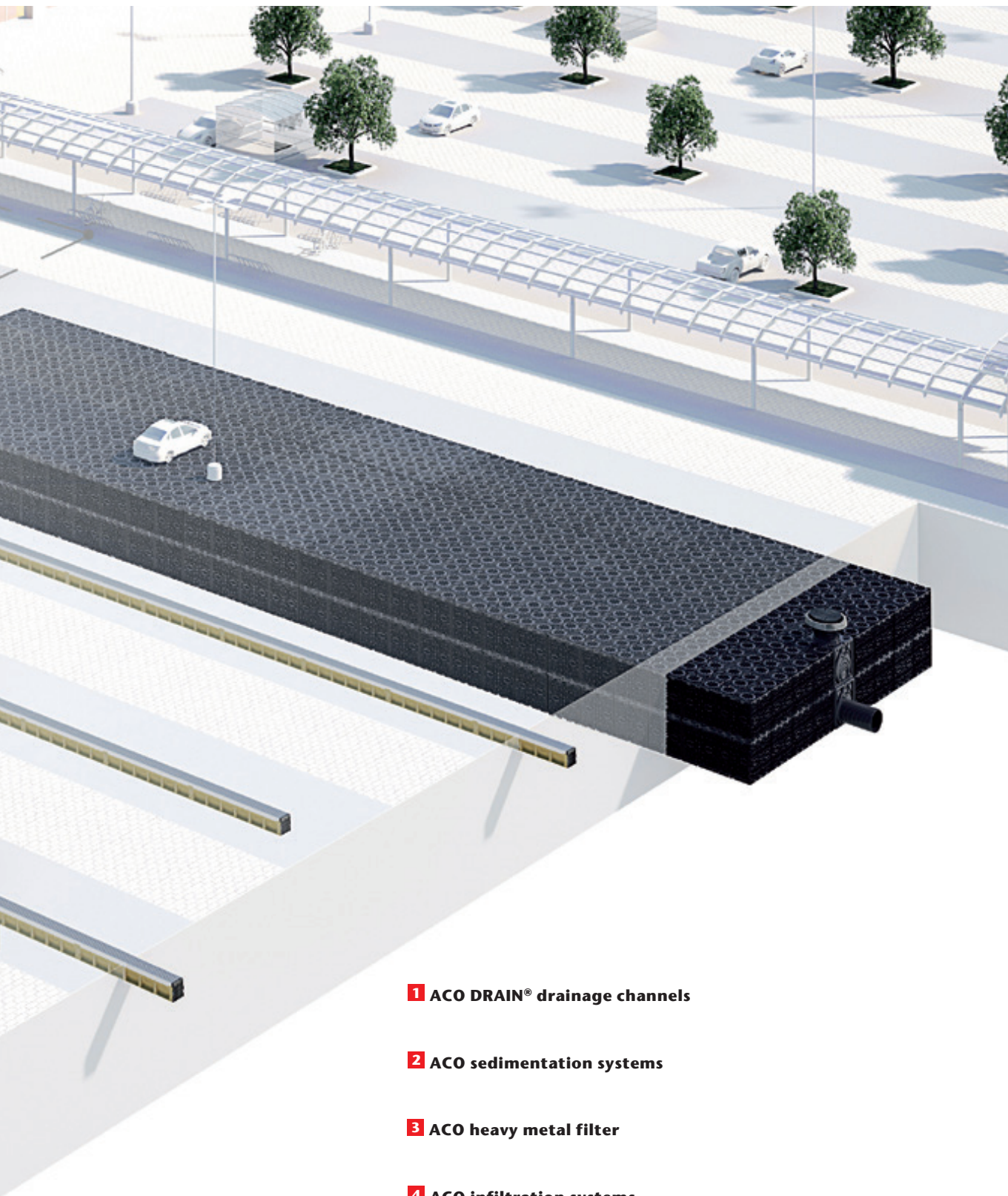

1 ACO DRAIN® drainage channels

2 ACO sedimentation systems

3 ACO heavy metal filter

4 ACO infiltration systems

Installation

Standard soil cover for installation of Stormbrixx SD

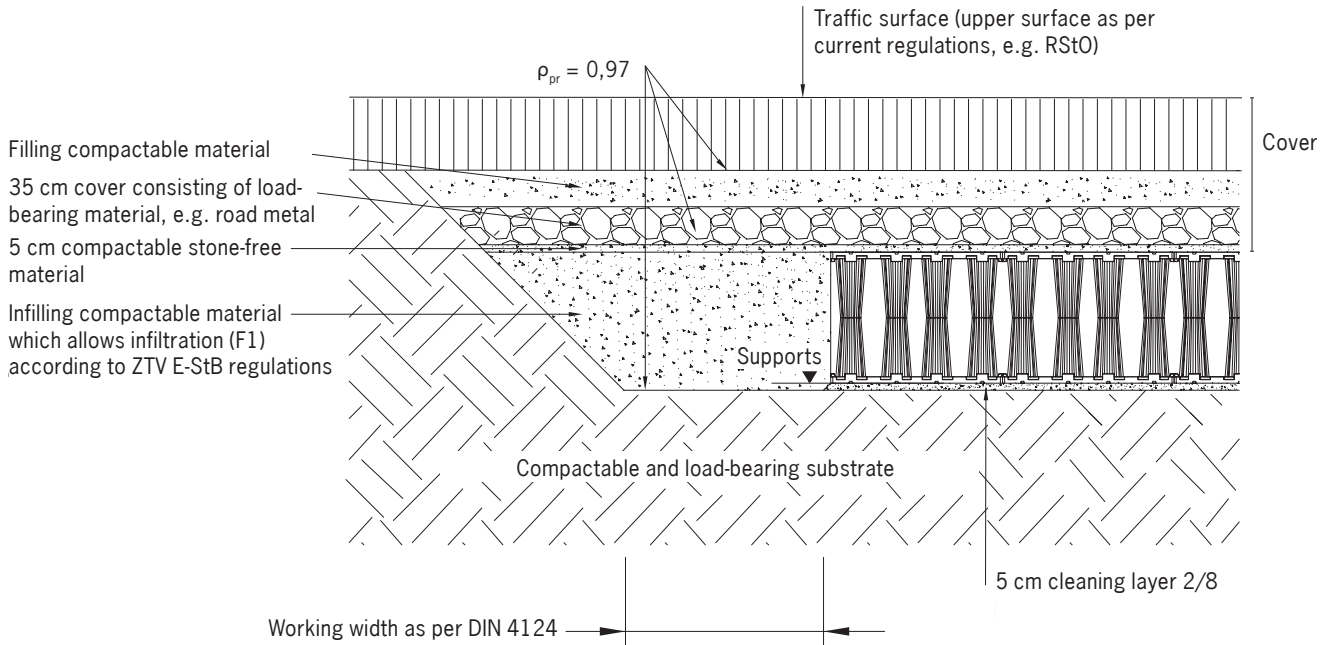

Installation dimensions Stormbrixx SD

| Layers | Walkable | | | Trafficable | | |
|--------|--|--|----------------------------|--|--|----------------------------|
| | Cover depth | | Installation depth maximal | Cover depth | | Installation depth maximal |
| | minimal ²⁾ [mm] ¹⁾ | maximal ³⁾ [mm] ¹⁾ | | minimal ²⁾ [mm] ¹⁾ | maximal ³⁾ [mm] ¹⁾ | |
| 1 | 800 | 2000 | 2914 | 800* | 2000 | 2914 |
| 2 | 800 | 2000 | 3828 | 800* | 2000 | 3828 |
| 3 | Please contact ACO Application engineering in your country | | | | | |

*Please consider the required road construction



**Standard soil cover
for installation of Stormbrixx HD**

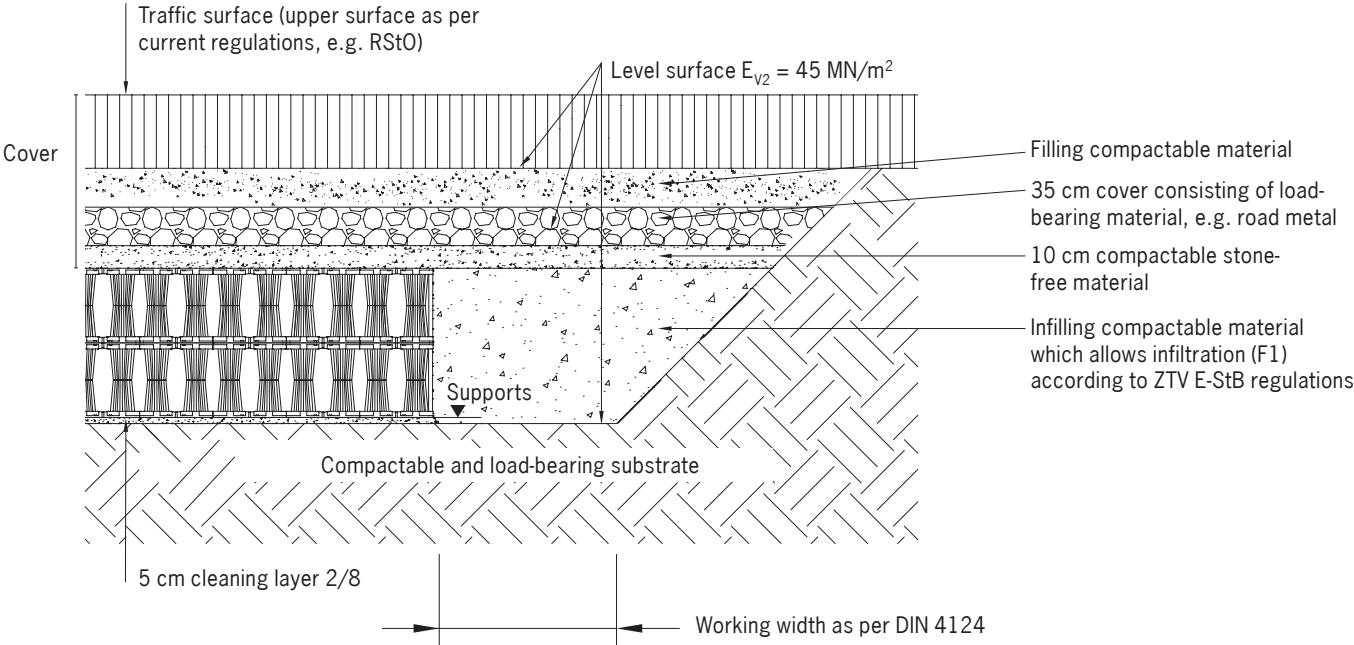

Installation dimensions Stormbrixx HD

| Layers | Walkable and trafficable | | | Trafficable with heavy traffic | | |
|--------|--|---|---|---|---|---|
| | minimal ²⁾ [mm] ¹⁾ | maximal ³⁾ [mm] ¹⁾ | Installation depth maximal [mm] ¹⁾ | minimal ²⁾ [mm] ¹⁾ | maximal ³⁾ [mm] ¹⁾ | Installation depth maximal [mm] ¹⁾ |
| 1 | 800* | 3400 | 4010 | 1000 | 3400 | 4010 |
| 2 | 800* | 3400 | 4620 | 1000 | 3400 | 4620 |
| 3 | 800* | 3400 | 5230 | 1000 | 3400 | 5230 |
| 4 | Please contact ACO Application engineering in your country | | | | | |

*Please consider the required road construction

To ensure the stability of the system, various requirements and standards must be observed when installing ACO Stormbrixx.

- 1) Ground cover consisting of cover and upper surface as per RStO regulations
- 2) Please allow for local conditions when defining the frost-free installation depth
- 3) Other cover depths for special cases should be agreed with ACO application technology



System configuration

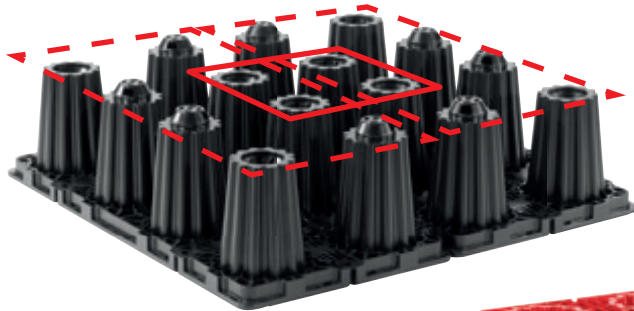

Linking blocks

The basic elements consist of eight columns, of which four are equipped with spigots and four with sockets.

They are easily assembled by plugging together the individual components. The basic elements are assembled with interlocking to optimise the positional safety of the overall system. To achieve this, four push-fit connections must be positioned next to each other.

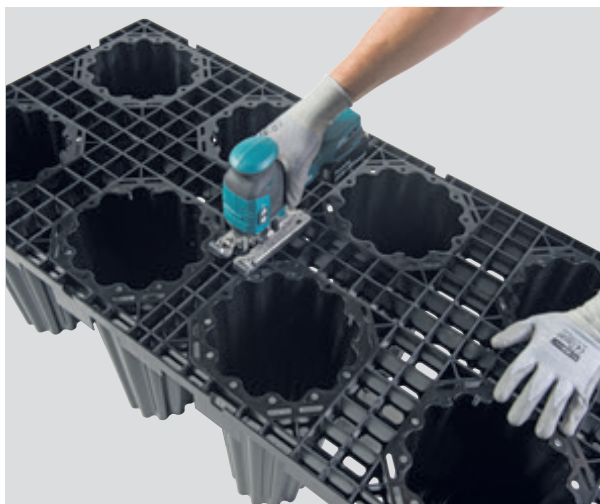

Halve the basic elements

ACO Stormbrixx basic elements can be bisected along their central rib using a handsaw or jigsaw. Each half can be linked to the rest of the system using connectors. The cut surfaces must face into the centre of the tank system.



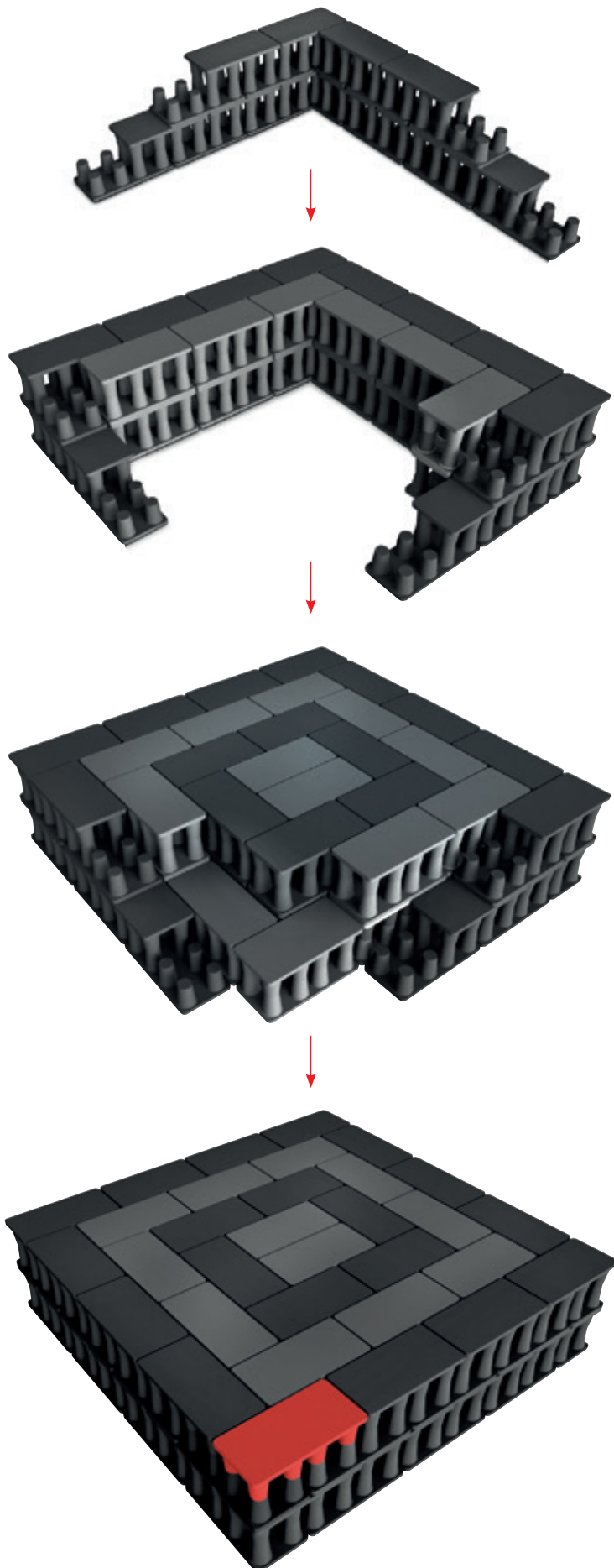

Recommended layout:

Concentric design

This is a series of rings, which become increasingly smaller as they approach the middle of the system.

1. Set out the outlines of the system and level the base of the excavation and lay a levelling layer of sand ($H = 5 \text{ cm}$) to form the formation.

2. Lay geotextile (filter nonwoven) and/or waterproof membrane if necessary
3. Set the outer perimeter of the infiltration system with basic elements.

Principle:

Two ACO Stormbrixx basic elements are placed on the ground. A third basic element is turned upside down and is laid on the first two elements in a block bond.

4. If necessary, cut half-basic elements to size
5. Repeat steps for all other layers.
6. Connect together the individual layers with the help of the connectors
7. For large systems (larger than 100 m^3), we recommend starting the installation from a corner, an end or a side. At the same time, begin assembling the inner rings.

If necessary, connect existing rings and layers with the help of connectors.

ACO Stormbrixx SD, half layer

Not every application case permits the installation of a complete layer of the ACO Stormbrixx infiltration drainage system. Areas with higher ground water levels can e.g. require the installation of a flatter infiltration drainage system.

A cover plate is available for ACO Stormbrixx SD for these cases, which thereby reduces the height of the block by almost half.

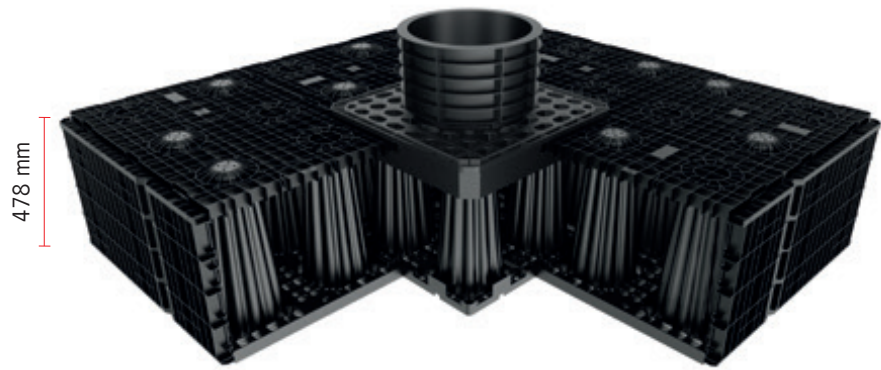

ACO Stormbrixx SD, cover plate for half layer
Article No. 314094

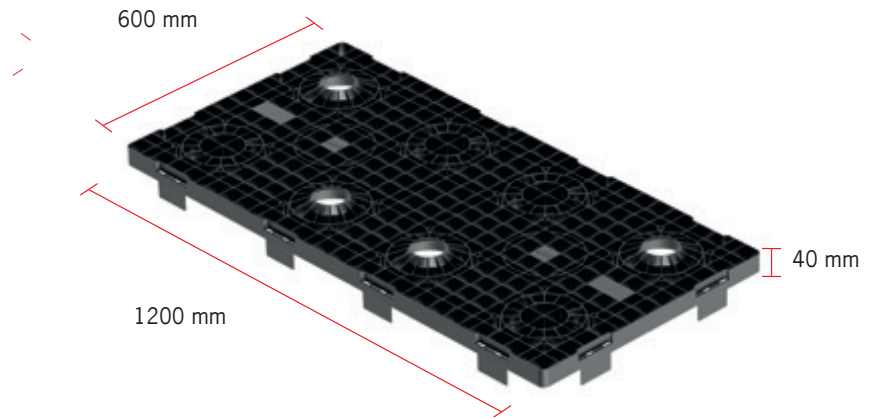

The sides of the infiltration drain are sealed shut with a ACO Stormbrixx SD half-sided wall
Article No. 314098
(On-site shortening of an ACO Stormbrixx SD side wall "full layer" is also possible as an alternative)



Pictorial representation

Rainwater seepage with ACO Stormbrixx SD 0.5 up to 1.5 layers

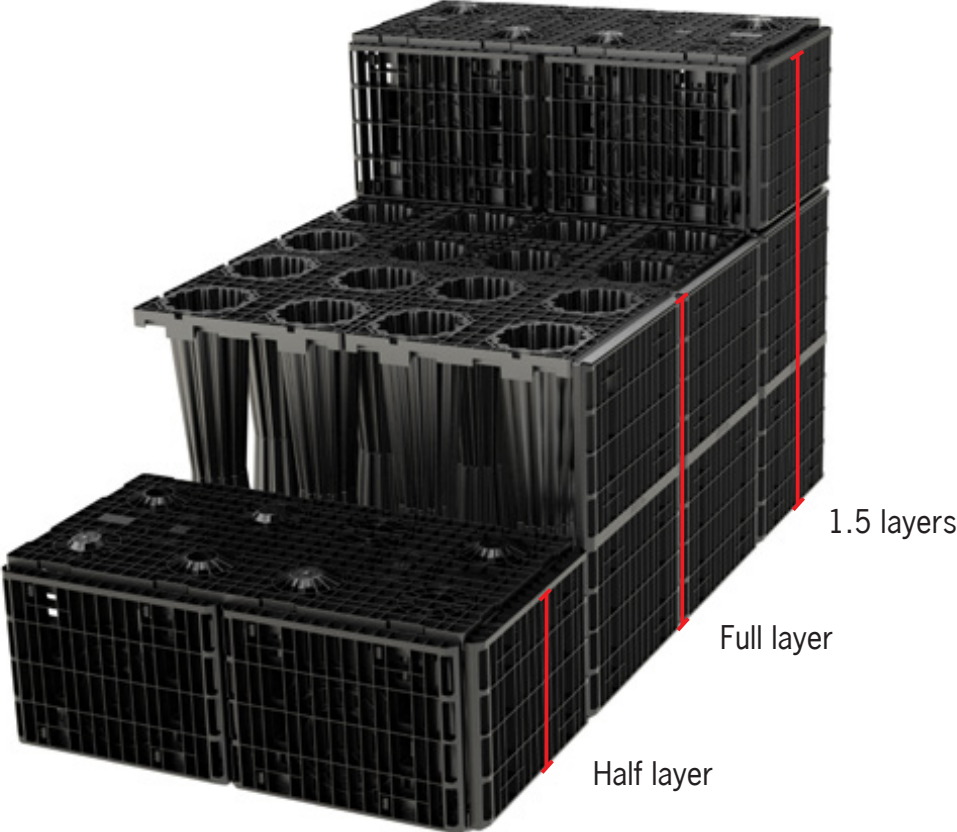

Rainwater seepage with ACO Stormbrixx SD half layer



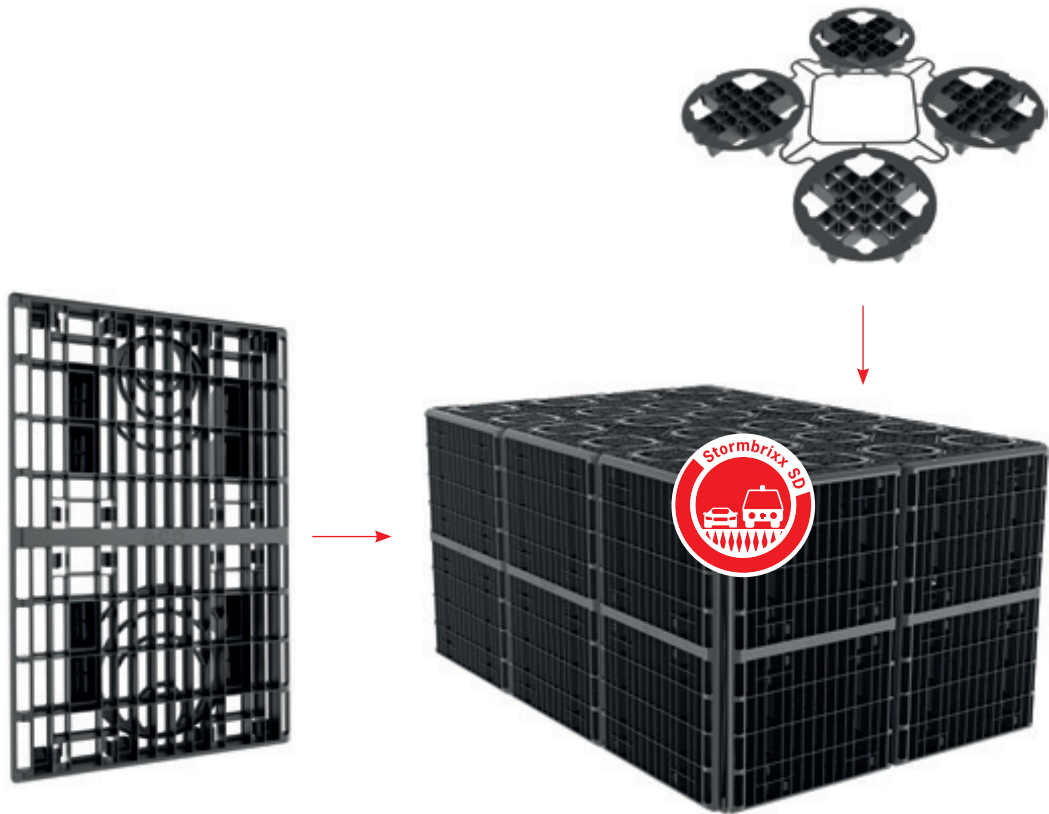

Side panels as the outer boundary



Covers close off the top layer



Side panel and top cover

The side panels are only used at the outsides of the block infiltration system. The covers are only used to close off the openings of the columns in the top layer. If necessary, pipe connections DN/OD 110–315 can be cut out in the places provided (markings).

Different side panels and covers are available for ACO Stormbrixx SD and HD.

Infiltration/attenuation system

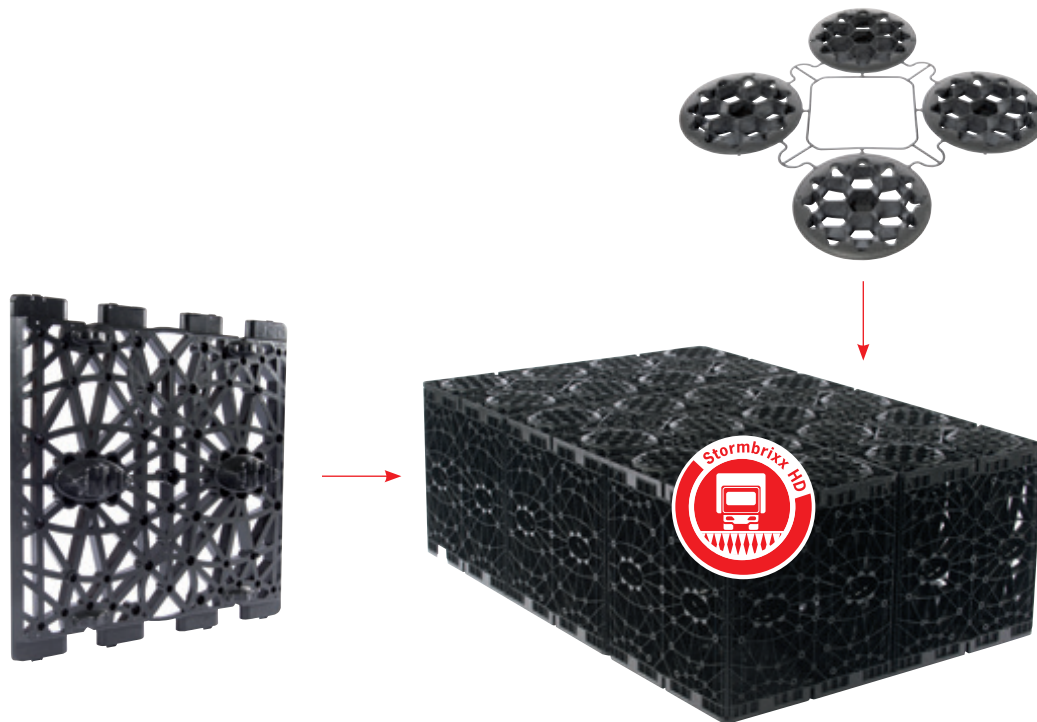

Side panels as a clean system surface for the enveloping geotextile

Covers prevent geotextile and soil from penetrating the system

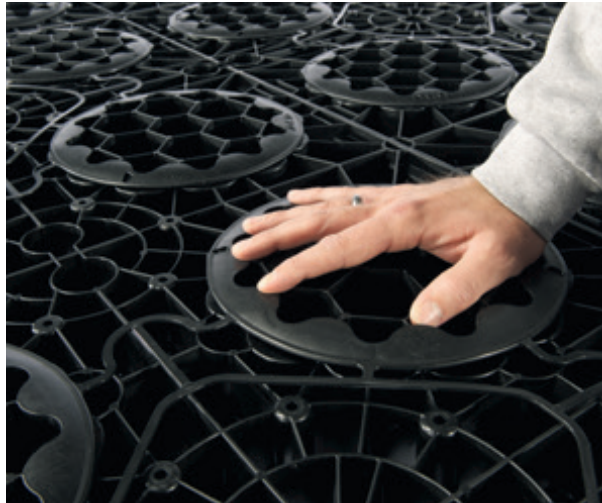
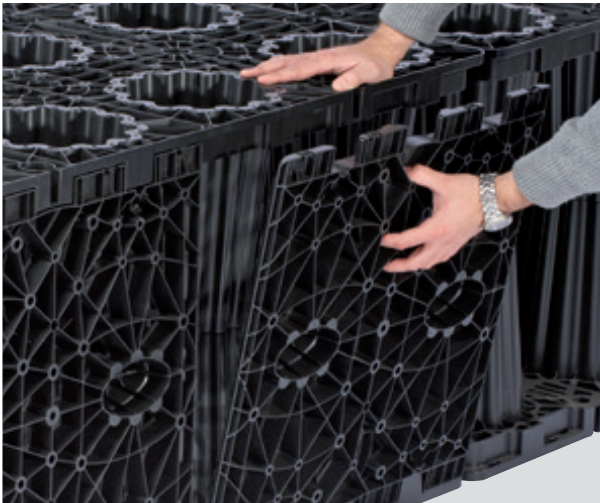

Installing the side panel

Easy assembly: The side panels latch into the basic elements and close off the outer border of the infiltration system. Due to the soil pressure, the geotextile cannot penetrate into the infiltration system.

Installing the top cover

Fast attachment: Four column openings can be closed off in a single step with the help of the ACO Stormbrixx cover. Covers are only mounted on the top layer of the basic elements, before installing the geotextile.

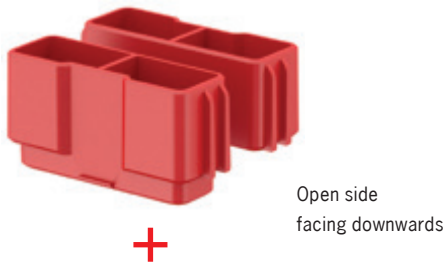

Open side facing downwards

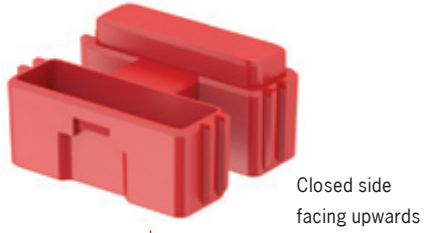

Closed side facing upwards

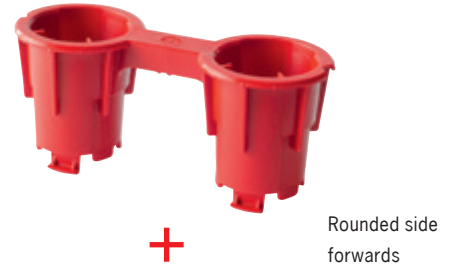
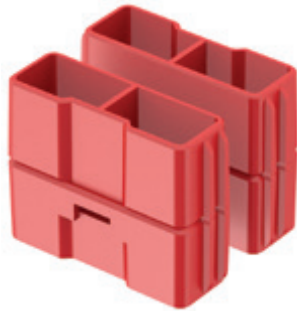

Rounded side forwards



Flattened side forwards

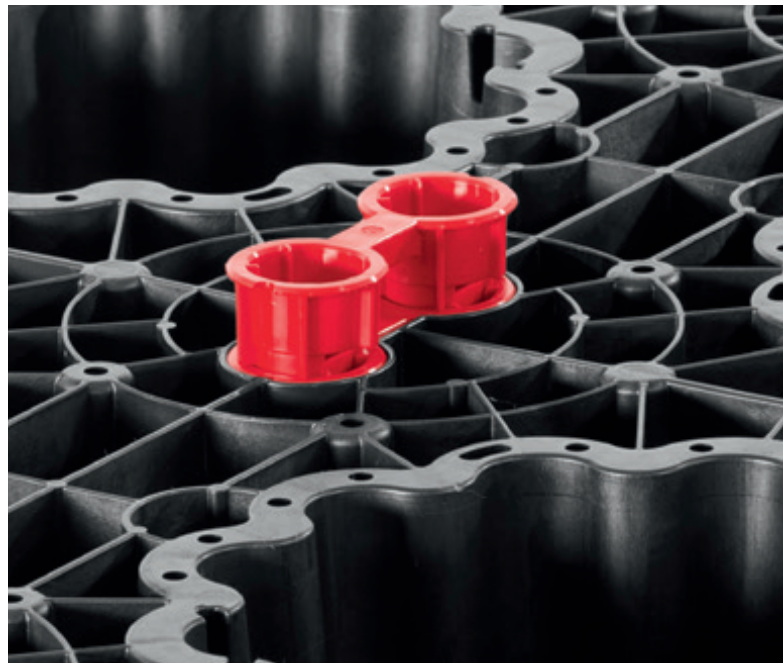
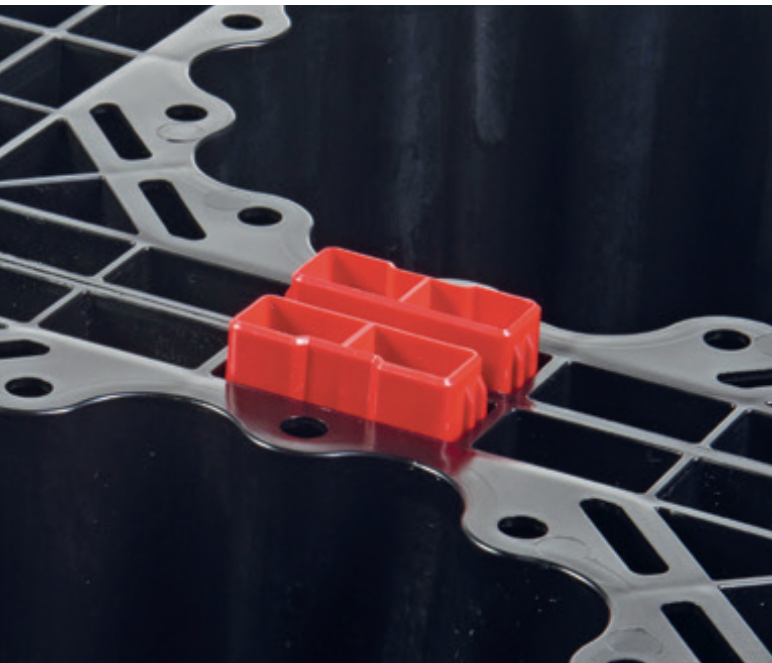

Connectors

When assembling two or three layers of ACO Stormbrixx, the layers are aligned and secured positionally by means of two connectors pushed together. The exact position of the basic elements and connectors within the overall infiltration system is shown in the laying diagram!

The connectors must each be mounted in the middle of the basic element.

Installing one layer

If only one layer of ACO Stormbrixx is installed, unlike other block infiltration systems, **no connectors** are required. Laying the basic elements in the interlocking bond or pattern (see page 32/33) provides additional stability for the overall system.

Installing several layers

Connectors are used if two or more layers of ACO Stormbrixx are installed: Two individual connectors are pushed together to form one and are inserted between the individual layers as positional fixing. This helps to achieve precise alignment of the spigots of several layers.

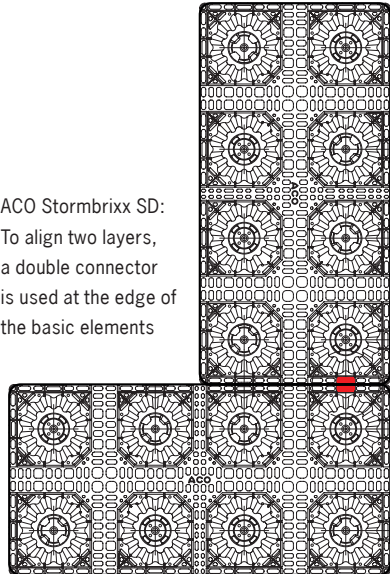

ACO Stormbrixx SD:
Two connectors pushed together secure the alignment of the spigots of two installation layers

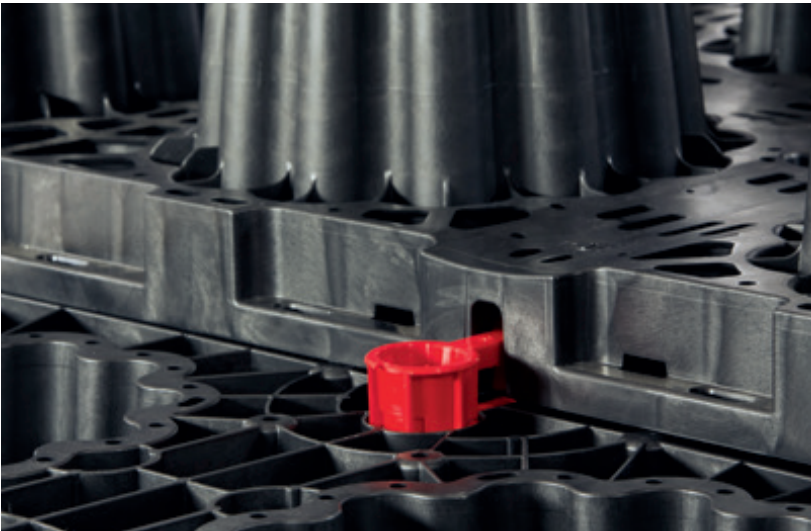
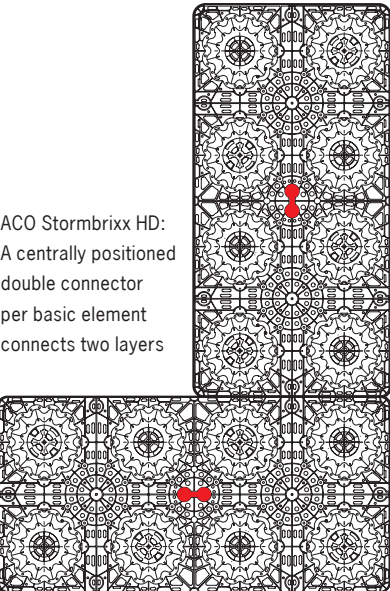

ACO Stormbrixx HD:
Two connectors pushed together secure the alignment of the spigots of two installation layers

Inspection and maintenance access

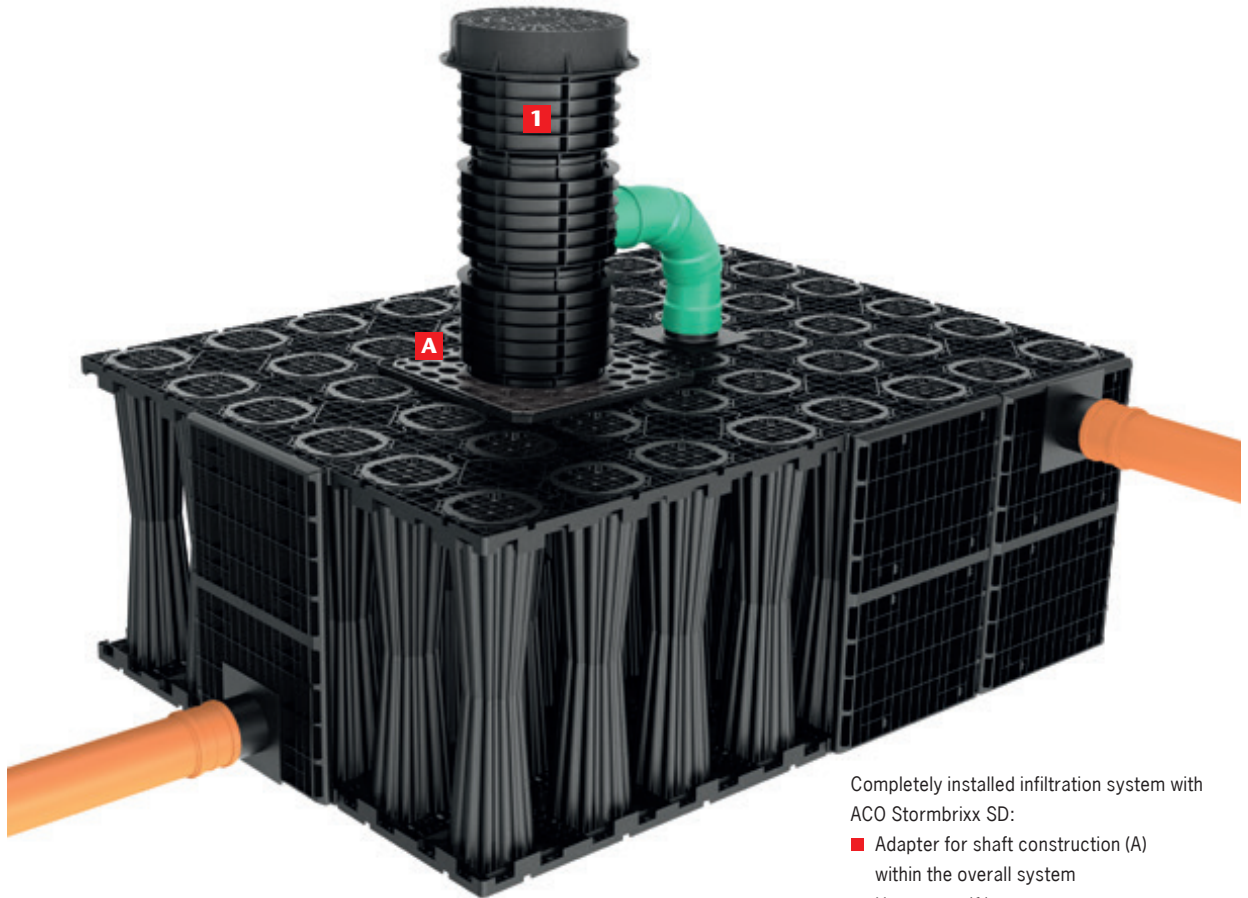

Completely installed infiltration system with ACO Stormbrixx SD:

- Adapter for shaft construction (A) within the overall system
- Upper part (1)

Entrance via access plate

The ACO Stormbrixx Adapter for shaft construction (A) is installed as an inspection access **within the block infiltration system**. An inspection shaft can thus be installed quickly and economically by simply assembling in the required place. The ACO Stormbrixx upper parts (1) are added to the top of the access.

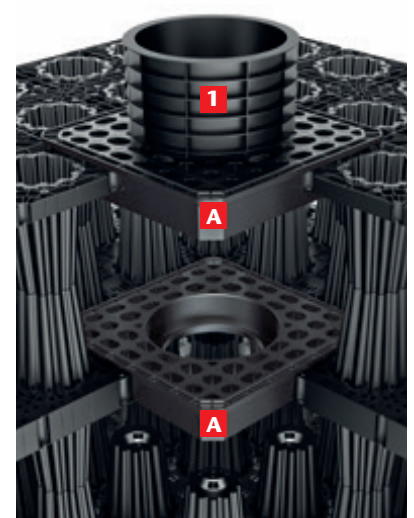
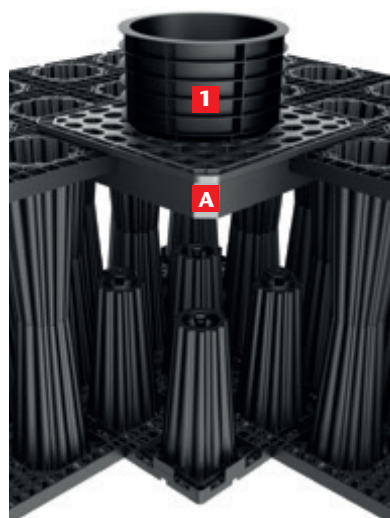

Infiltration system with ACO Stormbrixx SD:
The adapter for shaft construction (A) together with the ACO Stormbrixx upper part (1) is mounted within the overall system for inspection and cleaning of the infiltration system

Infiltration system with ACO Stormbrixx HD:
If accesses are required within the system, the adapter for shaft construction (A) can be used together with the upper part (1) as an alternative to the shaft base or intermediate part (B)

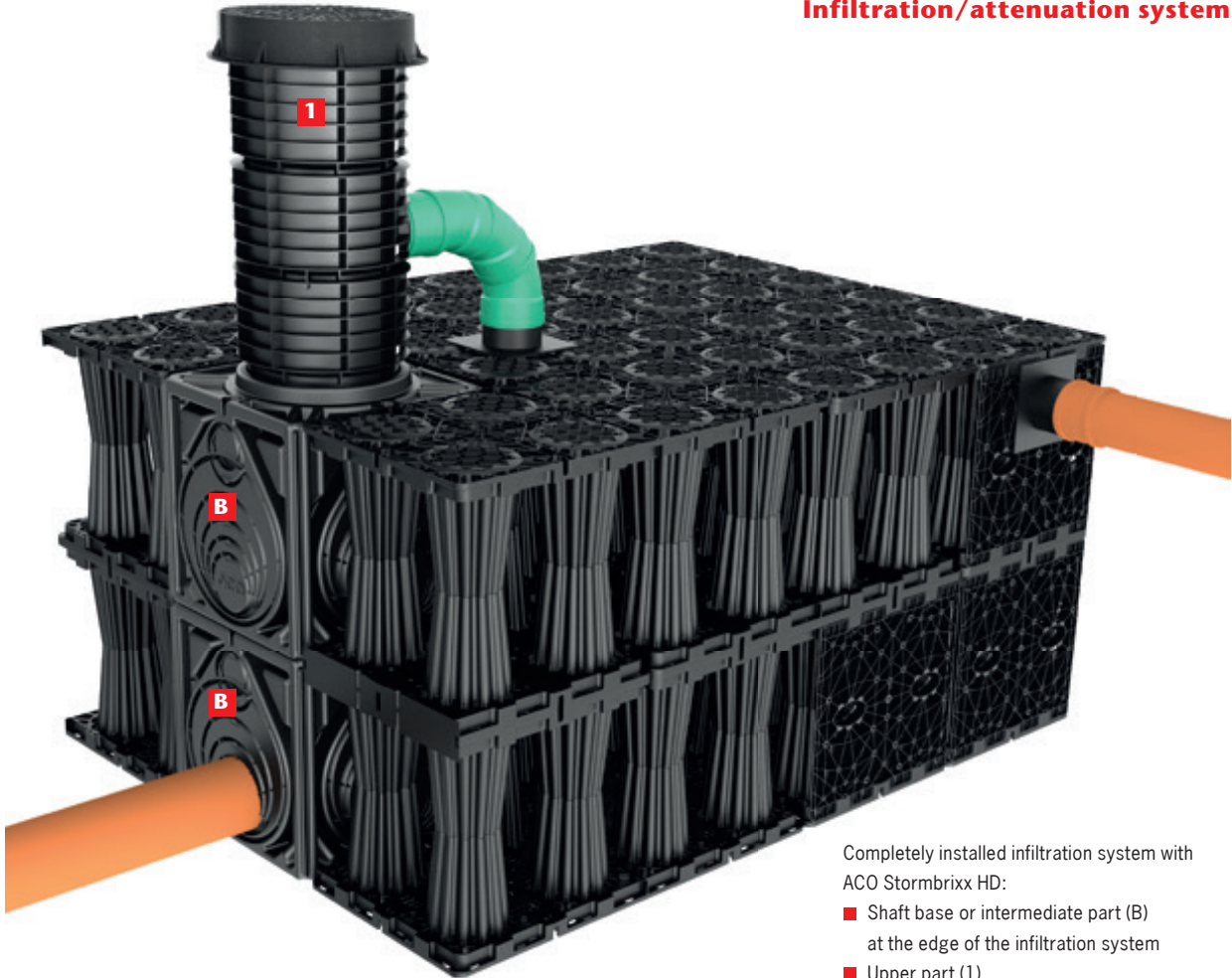

Completely installed infiltration system with ACO Stormbrixx HD:
 ■ Shaft base or intermediate part (B) at the edge of the infiltration system
 ■ Upper part (1)

Entrance via access chamber



For ACO Stormbrixx HD, the shaft base or intermediate part (B) can be integrated not only in the overall block infiltration system but also at the edge of the block infiltration as a connection and inspection shaft. In multi-layer infiltration systems the shaft bases and intermediate parts are simply assembled on top of each other.

Each shaft base and intermediate part can be cut out on site for different pipe size connections according to the in situ requirements (DN/OD 110, 160, 200, 315, 400).
 Tip: It is advisable to make a predrilled hole for the saw blade.
 The top of the shaft is added with ACO Stormbrixx upper parts (1). The height is variable and is adapted to the ground level. A shaft cover rounds off the modular system.

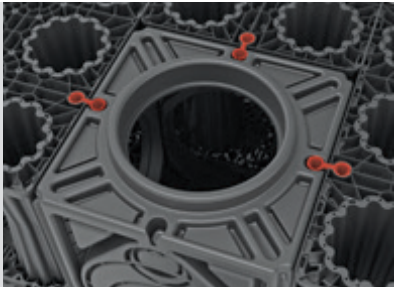

Only in conjunction with Stormbrixx HD!
 The shaft base and intermediate part can be used at the edge of the infiltration system for inspection and cleaning of the infiltration system. A lateral pipe connection DN/OD 400 can be made via this.

Shaft bases and intermediate parts are connected with individual connectors at the edge of the basic element.
 Do not use connectors on the underside!

Manholes

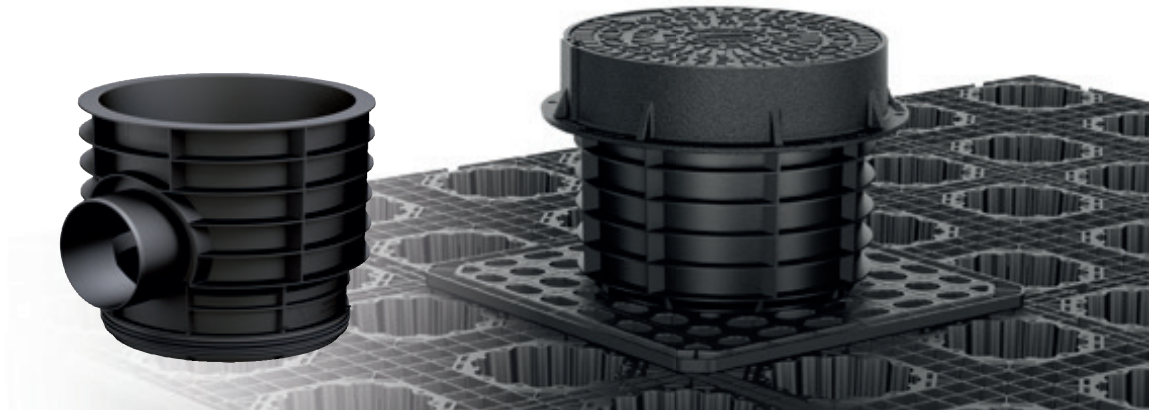

ACO Stormbrixx offers two options for accessing the system with a sewer camera or jetting nozzle or lance for inspection or maintenance of the block infiltration system (see page 60/61). Shaft upper parts enable access to the Stormbrixx system from the surface.

The upper parts with and without sockets can be rotated to match the pipe axis. Their push-fit connection can be adjusted to the longitudinal and transverse gradient on site and can be telescopically

adjusted vertically (+/- 30 mm). They are watertight up to 0.5 bar.

Load separation and vertical alignment of the individual components are ensured by the telescope principle. Any settlement that occurs in the backfill area can be absorbed by the tolerance window in the telescope. The load of the shaft cover is dissipated by the support of the shaft frame in a fresh concrete bed.

Caution!

- Before inserting upper sections, remove protective film from seal and clean it
- Seals must be coated with a suitable lubricant
- Upper section must be inserted to at least the minimum insertion depth!

Insert the upper sections



Drawing the inner diameter

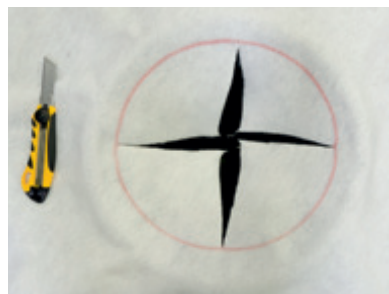

Cutting a cross within the marked circle

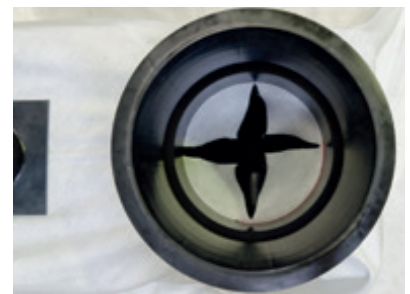

Installing the intermediate section (= sand tight)

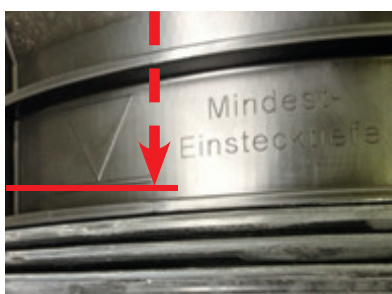

Insert to at least the minimum depth!



The temporary cover/formwork must protect the opening throughout the whole of the construction phase



Creating a ventilation:
A pipe elbow connects the upper part with the nozzle and the pipe connection adapter

Inspection via different access points



At the edge of the box
via the ACO Stormbrixx upper part
(inner diameter = 339 mm)
in connection with the access chamber
(inner diameter = 400 mm)

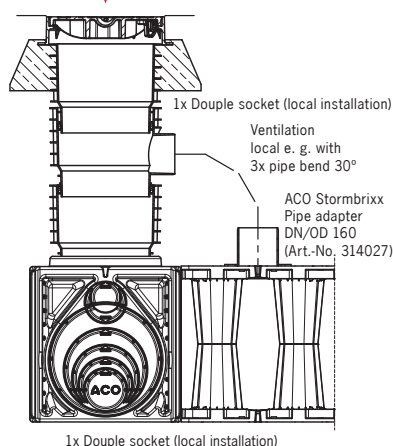

Within the box
via the ACO Stormbrixx upper part
(inner diameter = 339 mm)
in connection with the access plate
(inner diameter = 400 mm)

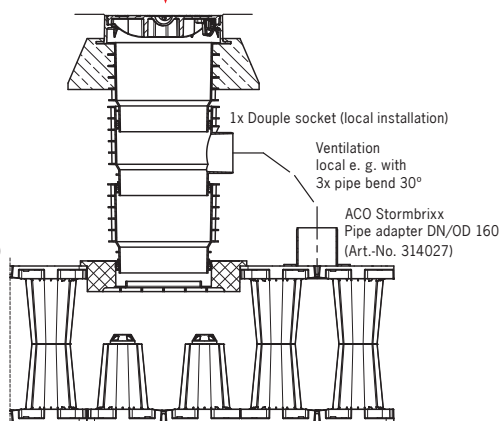

Within the box
via the ACO Stormbrixx upper part
(inner diameter = 339 mm)
in connection with the access plate
(inner diameter = 400 mm)

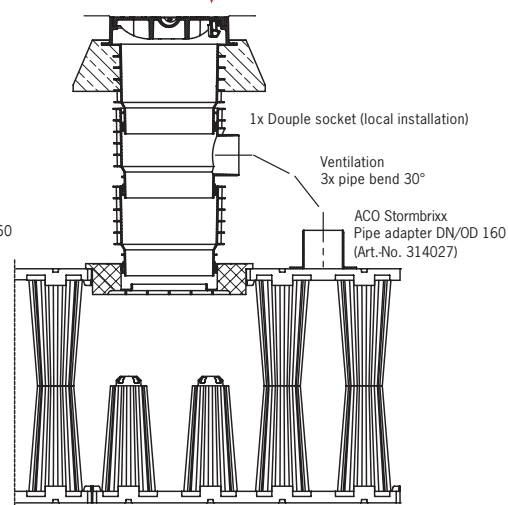

Shaft cover SA 400

The shaft cover has a maintenance free, screw-free and traffic-safe catch made from highly wear-resistant plastic (conforms to DIN EN 124 / DIN EN 1229, is stable at extreme temperatures, repels dirt, is self-locking and vandal-proof). Once the cover has been put in place, it can be locked into place by stepping on it vertically on the area sitting over the frame. A concrete seating surrounding the upper section provides the load transmission for the shaft cover. A concrete seating C12/15 approx. 20 cm wide is created all the way around, as defined by DIN EN 206-1, and raised by 2 cm to the highest drain upper section.

Use the inserted temporary cover/formwork to smooth off the inserted concrete flush. Then remove the temporary cover/formwork, press the frame into the wet cement base to a depth of approx. 2 cm until it is completely seated on the upper shaft section or as required for the final height.

After inserting the frame, it is possible to use a dirt bucket compliant with DIN 4052-B, low profile.

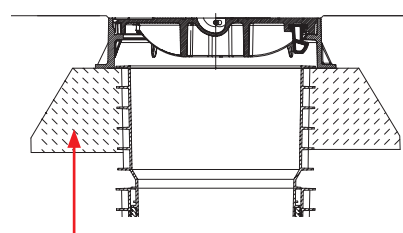

Depth of concrete: 20 cm
Concrete quality: \geq C12/15

Available with and without air vents



Making the pipe connections

ACO Stormbrixx pipe adapters must be used for the connection of inlets and outlets and ventilation pipes at the side panels of the infiltration system. Sizes from DN/OD 110 to DN/OD 315 are available.

Pipes size DN/OD 400 are connected laterally only via the shaft base or intermediate section of the ACO Stormbrixx HD infiltration system.



Install short pipe side in infiltration system!

Side openings

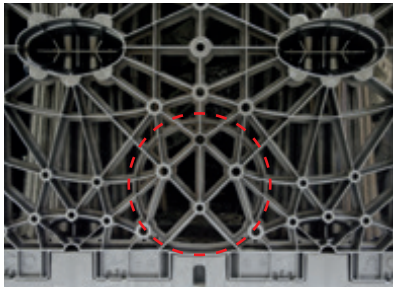

The openings for inlets and outlets must be cut out before installing the side panels



A keyhole saw with extra-long saw blade is required to cut out the pipe connection opening in the side panel

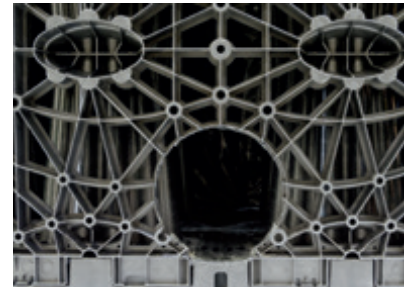

Top openings

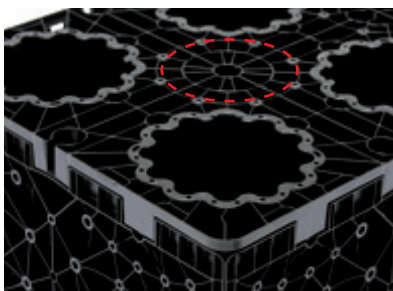

The openings for ventilation and the inspection openings must be cut out of the basic elements before they are installed



A keyhole saw with extra-long saw blade is required to cut out the openings for the pipe penetrations in the side panels and at the top of the basic elements

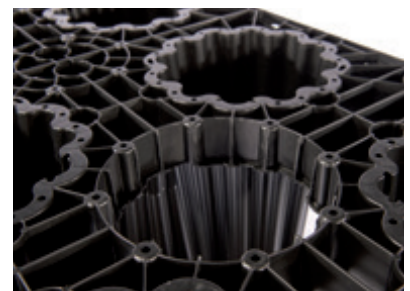



Markings on the side panels indicate the opening sizes for different pipe diameters



The pipe adapter is mounted in the previously cut out opening in the side panel



The geotextile is cut in and is pushed over the pipe adapter



The pipe adapter is mounted in the previously cut out opening at the top



The geotextile is cut in and is pushed over the pipe adapter

Pit excavation and surrounding the infiltration system

The soil must be load-bearing and sufficiently permeable for infiltration. In case of non-load bearing soil the geological conditions must be investigated and suitable measures taken. The load-bearing substrate must be stone-free, flat and without a gradient.

The bedding consists of the in situ soil or exchanged soil with a minimum load-bearing capacity of $EV2 \geq 45 \text{ MN/m}^2$ and an approx. 5 cm thick blinding layer (chip-

pings/gravel without fines) with grading range 2/8. This blinding layer must be drawn off flat.

The permeability of the soil must be ensured even after compaction. The quality of this bedding is decisive for the further laying and has a significant influence on the load-bearing and settlement behaviour of the hollow block infiltration systems, especially where a multi-layer structure is used or large loads occur (soil/traffic load).

The system must not be installed permanently or temporarily in in-situ groundwater, stratum or perched water. The relevant recommendations of the DWA-A 138 standards must be taken into account for infiltration systems. Accordingly, the distance to the mean highest groundwater level should be at least 1.0 m.

Infiltration – Laying the Filter Fleece

The entire block infiltration system must be surrounded with **filter nonwoven (geotextile robustness class: GRC 3, Weight: 200 g/m², Thickness: 1.9 mm)**. Before laying the basic elements, the nonwoven must be laid out on the blinding layer with sufficient overhang. ACO Stormbrixx is completely surrounded with the filter nonwoven, to prevent the penetration of fine soil fractions. At least 0.50 m overlap must be maintained on all sides of the infiltration system. Ensure that the nonwoven fits tightly on the ACO Stormbrixx system and soil does not penetrate between the components and the nonwoven enclosure.

The filter nonwoven is dimensioned as follows: Length of the nonwoven sheets = infiltration system perimeter + **at least 0.50 m overlap**. The two ends of the geotextile are temporarily and adequately fixed on the trench slopes or edges. After installing the ACO Stormbrixx components the filter nonwoven is detached from the trench slopes/edges and is placed over the infiltration system with overlap at the nonwoven joints. Ensure that the nonwoven fits tightly on the ACO Stormbrixx System and soil does not penetrate between the components and the nonwoven enclosure.



After creating a level surface which is free of stones, even and without gradient the trench is lined with a filter fleece.

Please note!

Take care that the overlaps are always at least 50 cm, that the fleece surface is completely sealed and that it cannot fall open during in-fill.

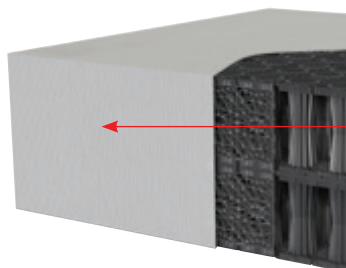

Geotextile, filter fleece, weight: 200 g/m²

Infiltration geotextile

- Geotextile robustness class GRC 3
- Weight: 200 g/m²
- Thickness: 1,9 mm
- Characteristic opening width: 0,08 mm
- Water permeability to EN ISO 11058: 90 l/sm²

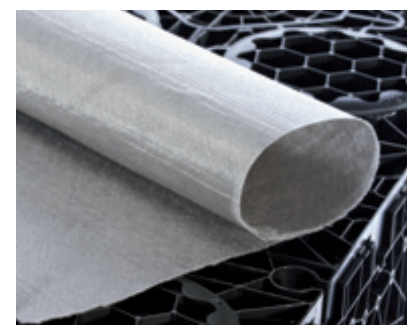

Attenuation – Laying the protective fleece and sealing membrane

If the modular ACO Stormbrixx infiltration system is used to retain surface water, the entire system must be surrounded by a **waterproof membrane (2 mm thick)** and welded. The waterproof membrane must be protected against mechanical damage by a **protective nonwoven (weight 400 g/m²) on both sides**.

The pipe adapters and shaft upper parts must be welded with the sealing membrane. The sealing membranes must be welded by examined qualified welders with testable welds in accordance with the DVS guidelines. The tightness of the welds must be verified and appropriate test records must be submitted to the client. The work must be carried out by a specialist company with examined plastic welder.

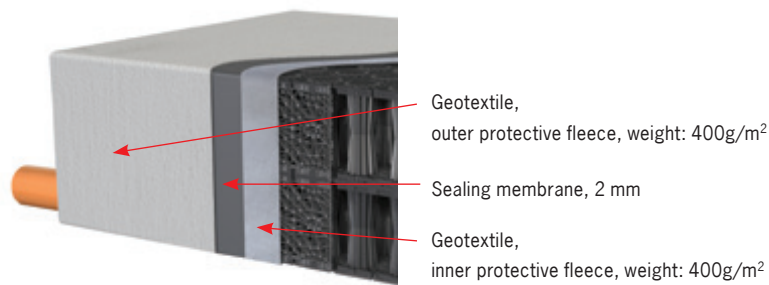

Important!

It must be ensured that the surface of the nonwoven and waterproofing is completely closed and no openings can occur during backfilling!



Covering over – Infilling

Recognised good technical practice, and applicable laws and standards must be respected (such as „Additional technical specifications and guide lines for soil works in road constructions“ (ZTV E-StB), „Directive for standardisation of upper surfaces for road constructions“ (RstO)).

Filling the trench sides

The stone-free infill material (which must meet DIN 18196) must be compactable and able to absorb percolated water. The coefficient of permeability of the infill material must at least match the calculated kf-value.

Side infilling is to be carried out according to DIN EN 1610, in layers no deeper than ≤ 30 cm each time, up to the upper edge of the trench.

Compact the fill material with a light-weight compactor to a Proctor value of approx. 97%. Avoid any direct contact between the compactor and the plastic components. The insertion of the infill material must not create any problematic distortion, damage or inappropriate loading of the trench system. Care must be taken when infilling and compacting that the overlaps of the geotextile are not disturbed and pulled apart, and that the ACO Stormbrixx system is not damaged!

Covering

After completing the infilling around the sides, a compacted covering of 10 cm of stone-free filler material and a 35 cm thick load-bearing layer of e.g. road metal are placed over the infiltration system to create a flat base for the subsequent structure.

Covering the ACO Stormbrixx system must be done in layers, tipping materials from the edge. For this e.g. a light-weight backhoe or wheel loader can be used with a maximum total weight of 15 tonne (4 double wheels). This equipment may only be driven over the site once it is covered by a sufficiently compacted layer with a thickness of ≥ 45 cm, while taking care not to create tracks.

For surfaces which will carry traffic the current road construction regulations apply (RStO). During and after the construction phase care must be taken to ensure that no dirt enters the infiltration system.

Please note!

Compaction using heavy vibrating rollers is not permitted! Driving construction vehicles directly over the ACO Stormbrixx system is not permitted! Driving heavy construction vehicles directly over the ACO Stormbrixx system is only permitted when there is a compacted covering at least 100 cm thick.



Planning instructions and technical regulations

The information in this brochure, our application technology consultancy advice, and any other recommendations are based on a large volume of scientific research and many years of experience. Nevertheless, they are only indicative, and designers and fitters remain responsible themselves for checking the products and the installation instructions in combination with all local circumstances, current technical regulations and the current state of the art of the technology, and we accept no liability.

ACO Stormbrixx is a modular infiltration system made from synthetic materials which, on the one hand provides bulk storage, and on the other hand is used to provide bulk percolation of storm water. The installation is carried out totally below ground level. Providing the correct earth covering is an essential part of this (see Page 42/43). The prerequisites for long-term operation are advance and careful planning, correct installation by professionals and where relevant connection to a functioning watercourse, together with regular maintenance/cleaning. The **standards for concrete** given in the ACO Tiefbau installation details are minimum values. Any special requirements which arise from local conditions (resistance to frost, road salt, chemicals, abrasion etc.) need to be taken into account by designers, applying the correct **choice of exposure class** as defined in DIN EN 206-1 and DIN 1045-2. For the selection and design in particular, but also for the installation of Stormbrixx, the following **technical regulations** apply in their current versions.

DIN 1045-2 „Reinforced and pre-stressed concrete structures – Part 2: Concrete – Specification, performance, production and conformity; Application rules for DIN EN 206-1“

DIN 4124 „Slopes, planking and strutting, breadths of working spaces“

DIN 18196 „Civil Engineering – Soil classification for civil engineering purposes“

DIN EN 206-1 „Concrete – Specification, performance, production and conformity“

DIN EN 1610 „Construction and Testing of Drains and Sewers“

DWA (German Association for Water, Wastewater and Waste) and ATV-DVWK (former name of above) work instructions

■ A 166 Structures for centralised storm water treatment and retention, 1999

DWA and ATV-DVWK fact sheets

■ M 176 Notes and examples for the design and equipment of structures for centralised storm water treatment and retention, 2001

■ M 178 Recommendations for the planning, construction and operation of retention ground filters for additional rainwater handling in mixed and separated systems, 2005

(In addition to the DWA rules listed on page 64)

RAS-Ew „Directives for Road Design – Section: Drainage“

RStO „Directives for the Standardization of Traffic Area Surfaces“

VOB (standard building contract terms) Part C:

ATV (general technical requirements) DIN 18299 „General regulations for construction work of all kinds“

VOB Part C: ATV DIN 18300 „Excavations“

VOB Part C: ATV DIN 18315 to 18318 „Construction of traffic-bearing roads; Surface courses without binder/ ... with hydraulic binder/... made of asphalt/ ... dry-jointed sett and slab pavements and surrounds“

Working paper „„Surface pavements with pavings and slabs by bonded construction“ ((Research Company for Roads and Traffic) FGSV-No. 618/2)

ZTV Asphalt-StB „... for the Construction of Asphalt Pavement Surfaces“

ZTV Beton-StB „... for the Construction of Concrete Pavement Surfaces“

ZTV E-StB „...for Civil Engineering for Road Construction“

ZTV Ew-StB „Additional Technical Terms of Contract and Directives for the Construction of Drainage Systems in Road Construction“

ZTV P-StB „... for the Construction of Dry-jointed Sett and Slab Pavements“ (without binder)

ZTV T-StB „... for the Construction of Base Courses for Road Construction“

The above list of regulations, standards and directives is indicative only for the design and implementation of line drainage in surfaces which bear traffic, and makes no claim to be exhaustive. To provide verification and certainty we recommend a local hydraulic test be organised on your site by ACO Application engineering. For special applications or for solutions which you do not see in this documentation, please contact ACO Application engineering. Our colleagues will be pleased to advise you and assist you in finding the best solution. Please contact them in your country.

Please also refer to the legislation and technical regulations on page 58.

Maintenance and inspection

Visual Inspection, maintenance and cleaning

Thanks to the intelligent building block architecture of ACO Stormbrixx, which requires only an external perimeter to the entire system using easy-to-erect side walls, the total volume of the installed infiltration system is accessible for inspection and washing.

Basically, maintenance work needs to be thought about during the planning phase. In detail, this may mean: in addition to the maintenance instructions we always recommend adhering to all the current relevant legal requirements (DWA-A 138 with instructions for the maintenance of infiltration systems)

During and after the construction phase care must be taken to ensure that no sediment enters the inlet pipes, shafts and the infiltration system. During and immediately after the construction phase an increase in the volume of sediment must be expected from the connected surfaces and must be counteracted.

Maintenance frequency

The initial inspection/cleaning of the ACO infiltration system should take place after completion and before handover, so forming part of the commissioning of the installation.

A visual inspection of the shafts and a camera passage through the pipes and the infiltration system is recommended. The results should be recorded in an operating logbook.

To guarantee long-term operability, the recommendations of the current relevant legal requirements must be respected (DWA-A 138, instructions for the maintenance of infiltration systems).

A visual inspection must be carried out at least twice a year, preferably in the spring (high pollen levels) and autumn (falling leaves). If necessary, maintenance/cleaning should be undertaken.

The operator is responsible for ensuring that all maintenance work is carried out by qualified expert staff, who are fully aware of the maintenance and operating instructions.

Relevant accident prevention regulations must be respected.

The results of the inspections carried out can then be used to determine the frequency of maintenance interventions in future.

If unusual weather conditions occur (heavy rainfall or similar), additional inspections and/or maintenance are recommended.

The inspection equipment can be moved freely through the trough-shaped indentations in the base plates of the system



Camera, jetting nozzle

The inspection and cleaning accesses, consisting of shaft bases, intermediate sections and upper parts, provide an easy way for sewer cameras, jetting nozzles and jetting lances to access the ACO Stormbrixx hollow block infiltration system (see page 50–53).

Cleaning

The cleaning of the ACO Stormbrixx infiltration system can if necessary be carried out using sewer cleaning equipment (sewer cleaning technology/high-pressure washing). The maximum water pressure must not exceed 100 bar.

The water can be sucked out through the upper sections and the lower and intermediate shaft sections.

When disposing of the cleaning water/sediment all applicable legal requirements must be observed.

Visual inspection

Visual inspection includes the following points:

- The condition of the infiltration space (side walls, bases, covers, columns)
- Connecting pipes

If there are signs of leakage, the watertightness of the system must be re-established by suitable tests.

Maintenance measures

If faults are detected during the visual inspection (dirt, distortions etc.) these must be corrected immediately.

Operating logbook

The results of the visual inspection and any maintenance and repair measures undertaken must be recorded in an operating logbook. These records then allow decisions to be made about the necessary frequency of future visual inspections and maintenance measures.

The following data and information must be recorded in the operating logbook:

- Completeness of the operating log book
- Date of visual inspection or maintenance work
- Identity of staff involved
- Problems arising (also causes of problems)
- Measures taken

Keeping a logbook has many benefits, e.g. traceability of sources of problems, targeted error analysis and determination of follow-up measures.

Warranty

Please refer to the relevant section in the general terms and conditions of sale of the ACO company in your country.

Vertical access directly through the system



Push camera, cleaning equipment with a rinsing



Self-propelling camera



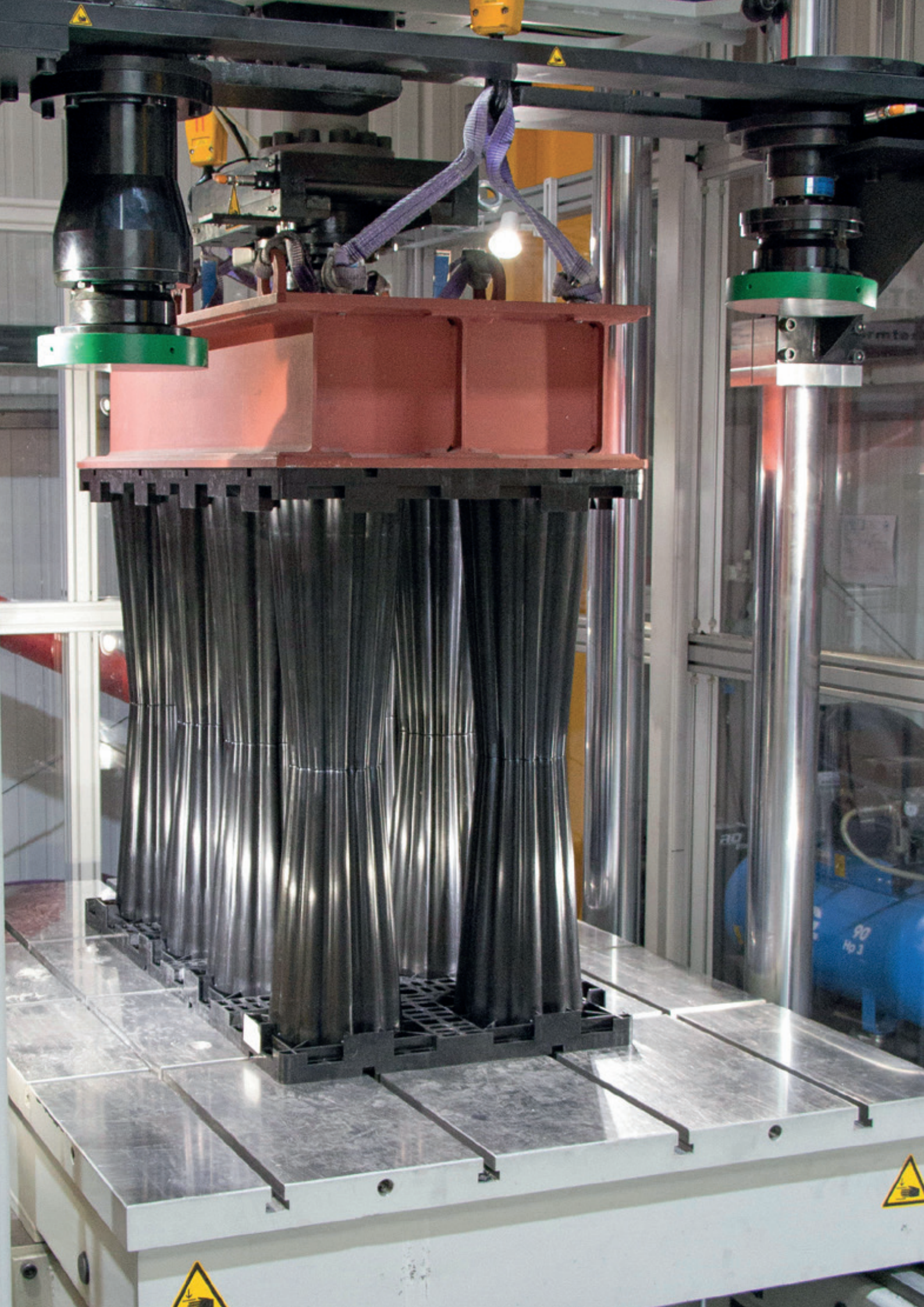

FEEL SAFE WITH US

50
YEARS

Product testing

According to the installation conditions ACO Stormbrixx systems provide a product safety, which is designed for 50 years in accordance with DIBt guidelines.

ACO Stormbrixx HD is DIBt-certified. ACO Stormbrixx SD has been tested by the Gesellschaft für Materialforschung und Prüfanstalt für das Bauwesen Leipzig mbH, Germany.

Regular material and product tests ensure continuous quality.



The specifications in Germany:

Legislation and technical regulations that support solutions

Over the past few decades, draining the accumulated surface water to the watercourse as quickly as possible became an overriding goal. Today, the aim is to enable rainwater to seep, or to recycle it, as well as to keep sealed surfaces to a minimum: surface water should seep away where it falls. Statutory rainwater charges are now levied for sealed surfaces in practically all regions of Germany. If securing surfaces is unavoidable, rainwater can be managed by means of infiltration and storage.

German Water Resources Law

Both the EU Water Framework Directive and the German Water Resources Law establish clear requirements for handling rainwater.

“Surface water should seep away or be irrigated locally, or be routed into a watercourse directly via a sewage system, without being mixed with grey water, provided that this does not contravene legal requirements on water or other regulations under public law, nor come into conflict with water management issues”

(Section 55 German Water Resources Law of 01.07.2009).

As well as this, German federal states as well as municipalities, towns and cities define their own specifications and regulations that building owners, planners and land owners are required to adhere to.

DWA set of rules

The following rules must be considered when dimensioning infiltration systems and surface water attenuation facilities:

- Standard DWA-A 138
“Planning, Construction And Operation Of Facilities For The Infiltration Of Precipitation Water”. Applies to the infiltration of precipitation that falls on permeable and impermeable secured surfaces. This serves as an essential foundation and must be taken into account for every infiltration system.
- Standard DWA-A 117
“Dimensioning Of Storm-Water Holding Facilities”. Applies to general waste water drainage between land drainage and watercourses.
- Advisory Leaflet DWA-M 153
“Recommended Actions for Dealing with Storm Water”. Provides recommendations for pre-treating rainwater before it is allowed to seep away or routed to a watercourse.



How to control the discharge rate to the required level?

ACO control systems

More frequent rainfall events and more intense storms require a change in our approach to managing the resulting surface water. If rainwater cannot be infiltrated at the source, it must be stored temporarily and discharged into the outfall in a controlled way.

In order to reduce the rainwater drainage from the rainwater retention basin, throttling devices are used, e.g. static faceplate, swivel throttle and pump stations. These flow restricting elements can be used to reduce flow rates to a more sustainable level into receiving waters or downstream sewers.



ACO Flow Control

Controlling the quantity of discharging surface water



ACO Q-Brake

Vortex restrictor system for controlled discharge

ACO's concrete flow-restriction disc made of a corrosion-resistant stainless steel regulates the discharge volume from the rainwater retention basin. It is equipped with a line scale for setting and displaying the slide plate opening height and a telescopic spindle extension with square drive and spindle holder.

Page 62

ACO's Q-Brake vortex throttle is a vertical vortex throttle downstream control mechanism which has been designed to regulate rainwater before it is discharged into receiving water or sewer pipes. Unlike conventional mechanisms, ACO's Q-Brake vortex throttle is less susceptible to blockages and enables higher flow rates even at low retention levels.

From Page 64

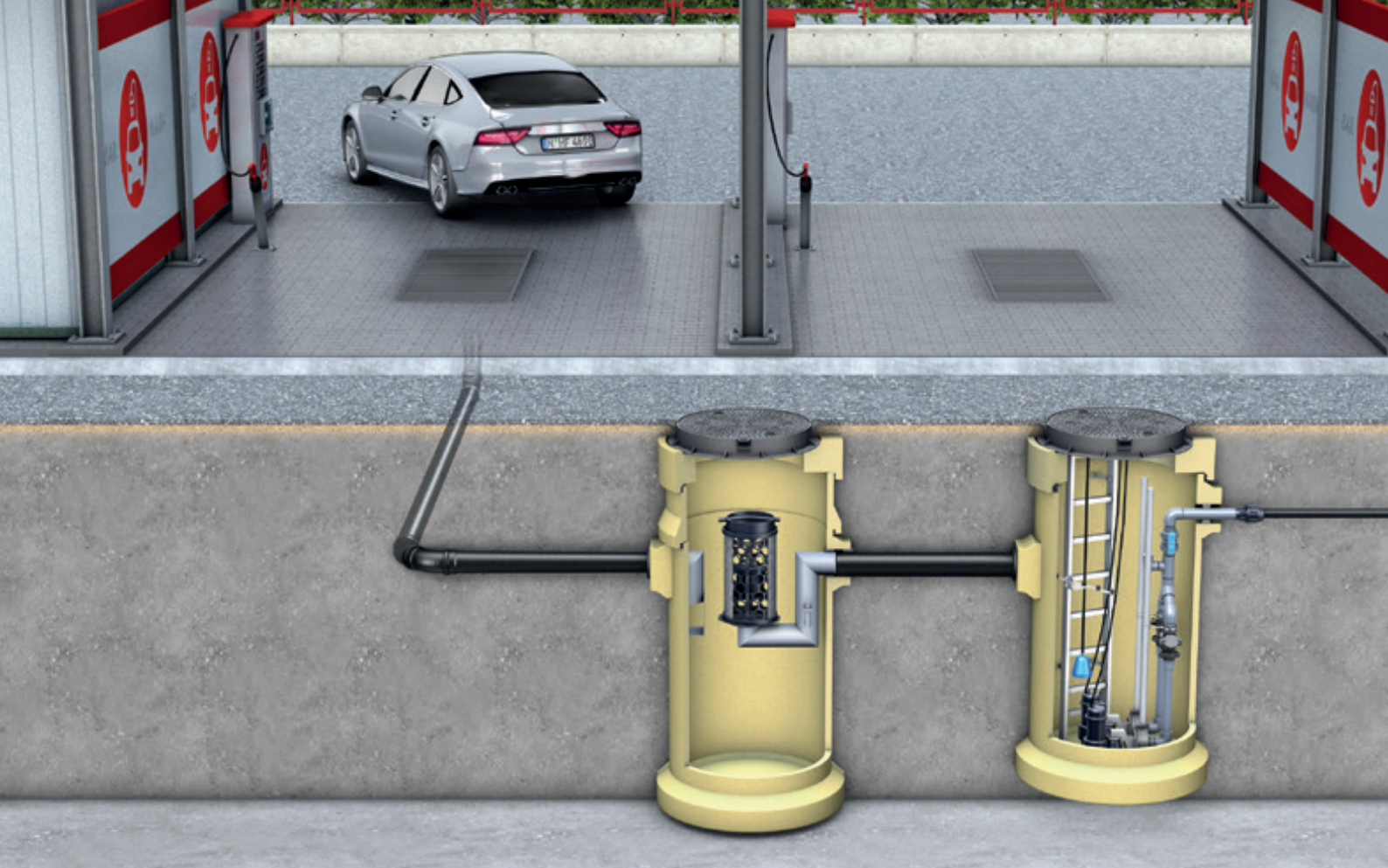

ACO Powerlift Pro
Pump shaft

ACO Pump shafts

ACO's pump shafts elevate discharged wastewater from subterranean installations to the level of the public sewer system. Backlog is therefore eliminated, even when drains and sewers have flooded. ACO pump shafts are designed for problem-free and economical waste water drainage in municipal, industrial and domestic areas. The pumping stations are delivered pre-assembled to the construction site. The volume of wastewater and other criteria determine the size of shaft and the type of pump.



Throttle slide

Regulating the quantity of discharge rainwater

ACO's flow restrictor manhole is used to control the discharge volume from the stormwater retention basin via shaft structures made from reinforced concrete. These comprise built-in flow restrictor gate valves or penstocks to reduce the cross-sectional size of the outlet. The resulting reduction in flow rate prevents overloading the sewers. Retention basins are the conventional method managing downstream flows. They should run empty after the end of a storm event so that they are available for the next.

Controlled emptying of the retention basin is preferred to prevent downstream damage, e. g. high flow velocities. Furthermore, restricting flow into receiving waters will prevent drifting of organisms, back erosion or similar impacts.

Protecting public sewers

Product benefits

- Compact, flat flow control valve
- Corrosion-resistant stainless-steel structure of material grade 1.4301
- Scale for adjusting and displaying the valve plate opening height
- Telescopic spindle extension with square drive and spindle bracket
- Available systems: 2–256 l/s

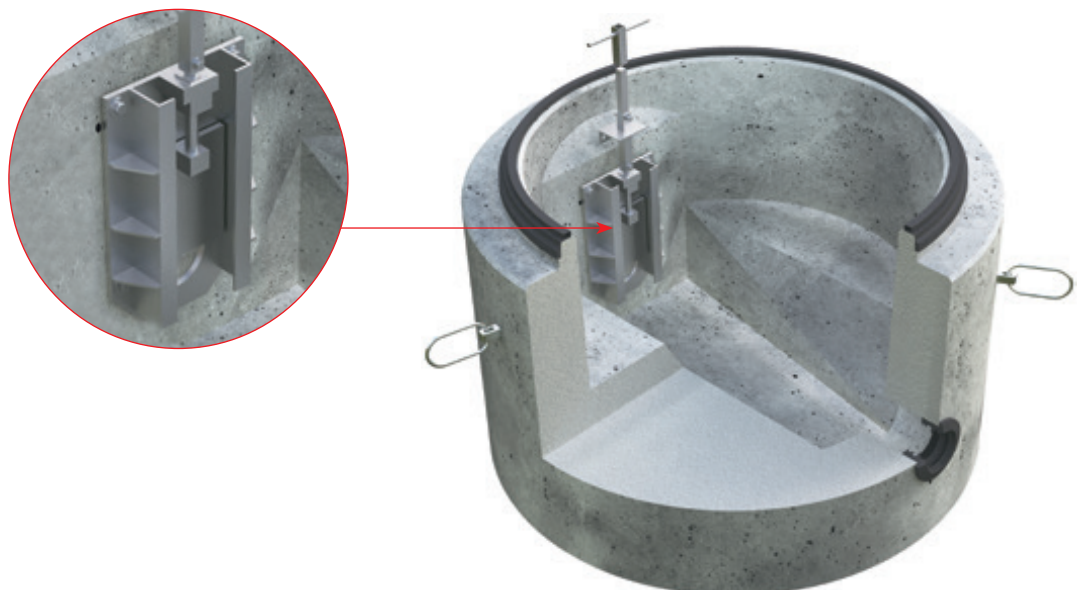

Regulators

Surface water retention basin with discharge controller

ACO's Regulator discharge controllers are installed in surface water retention basins. Their role is to constantly discharge a defined wastewater flow from the basin. When water levels are between 0.6 m up to h_{max} , upstream flows vary max. $\pm 10\%$. If the flow (l/s) discharging into the retention basin is temporarily larger than the quantity discharged by the discharge controller, the water is stored temporarily. The stored quantity is then reduced when the flow into the retention basin is less than the flow out of it through the regulator discharge controller. The discharge controller is designed so that the water in the retention basin is always removed at the surface. This ensures continuous evacuation of floating oil particles.

Regulator discharge controllers must be set to a fixed pre-calculated value when designing the retention basin. This results from the design is based on the data from DIN 1999 Part 2 and Part 4 and is equal to half the nominal size of the separator to be installed; i. e. the separator is only loaded with half the flow, based on the nominal size. This take into account a safety factor, as the wastewater drawn from the surface of the retention basin is usually contaminated with oil.

Discharge controllers are not designed to cater for any sediment sludge, as they are restored from the surface. The sediment material is separated in the sludge collection chamber of the retention basin, which must be located in the inlet area of the retention basin. (If the ACO Type PR-18 regulator basin is used, a required sediment trap must therefore be located upstream or downstream of this regulator basin.) Alternatively, the discharge controller can also be installed at half the basin height. The space below the regulator is then used as a sludge collection chamber. However, this reduces the intermediate storage capacity of the system.

Regulators are individually designed by ACO's civil engineering application engineers. Please contact them in your country.

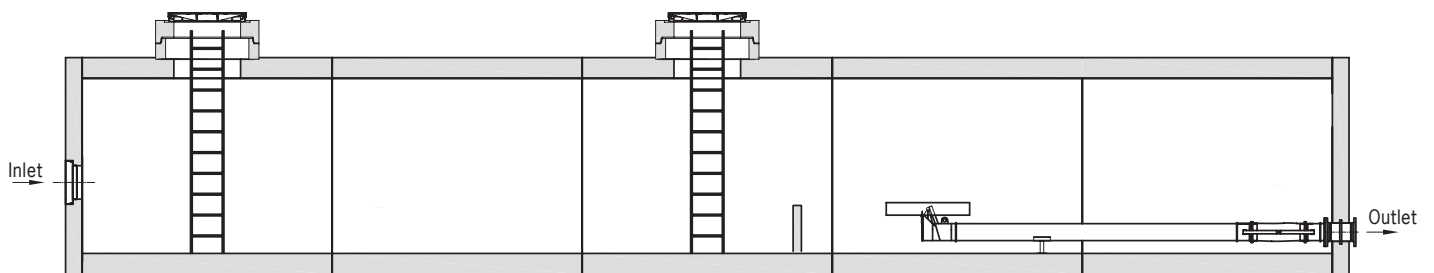

Surface water retention basin with ACO Regulator discharge controller

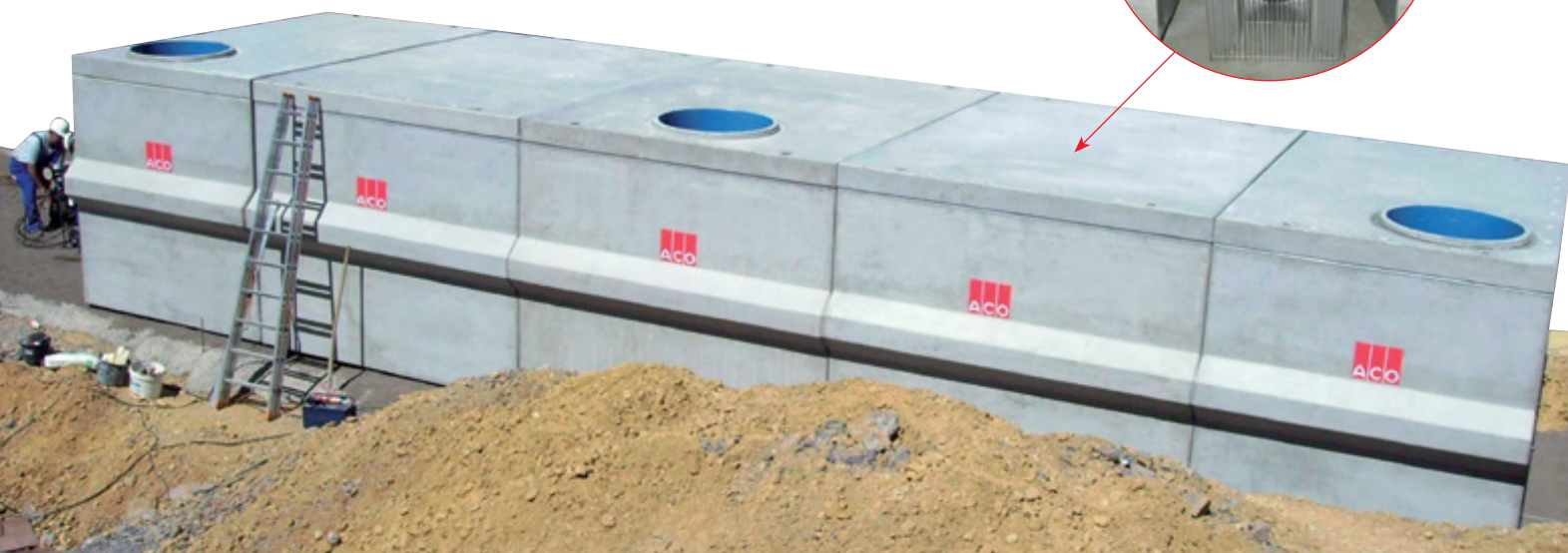

ACO Q-Brake vortex throttle system

The ACO Q-Brake vortex throttle is a vertical vortex throttle downstream control mechanism which is designed to regulate rainwater before it is discharged into receiving water or sewer pipes. Unlike conventional methods, such as vortex apertures or with purpose dimensioned pipes, the ACO's Q-Brake vortex throttle is less susceptible to blockages and enables higher flow rates even at low upstream retention levels. With a water flow controlled by a vortex throttle, a larger discharge opening (up to 6 times) is possible than with conventional systems.

What is the ACO Q-Brake vortex throttle?

The design of the vortex throttle flow control is based on the liquid-mechanical principle of a strengthened vortex which enables a throttle discharge flow without the need for moving parts.

The ACO Q-Brake vortex throttle utilises the upstream water gauge and empties itself to generate a "vortex" within the structure of this mechanism. The mechanism is assembled when a built-in bypass flap that opens when blocked so that the water can drain. A stainless steel cable and the bypass are utilised for controlling this. If the water level drops below the aperture opening, then the upstream system can operate until completely empty.

The ACO Q-Brake vortex throttle is manufactured from V2A stainless steel and individually configured to fulfil specific performance criteria. All joints are continuously welded for guaranteed maximum stability and durability.

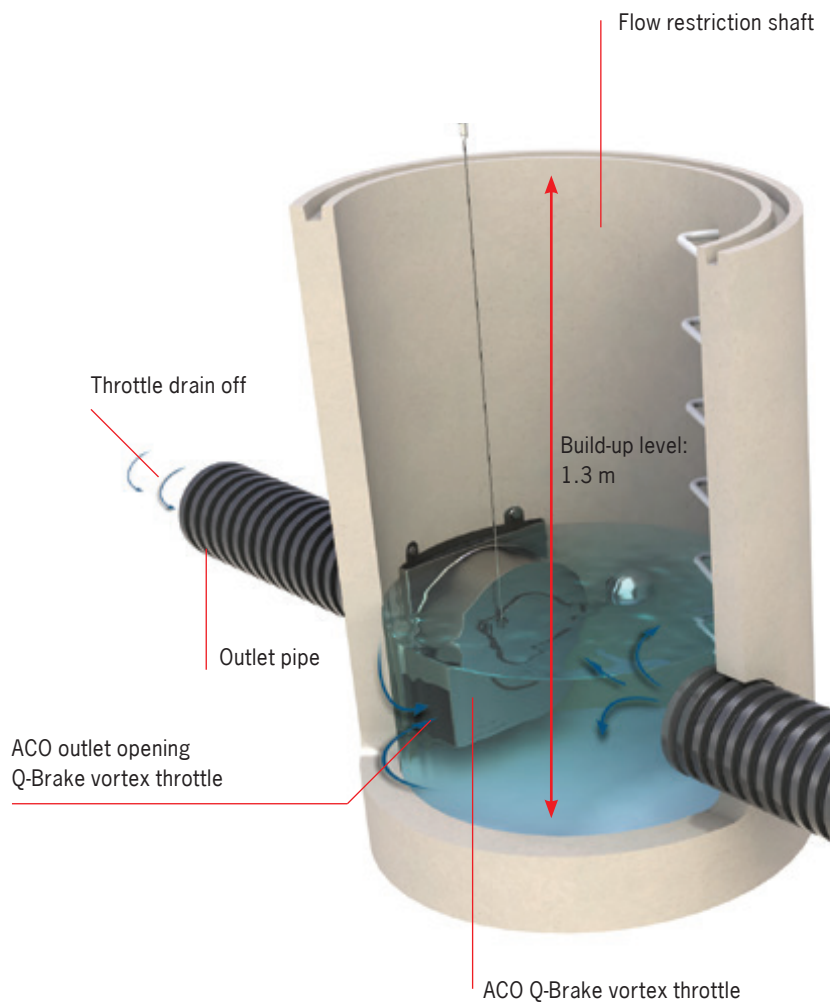

Q-Brake is adaptable to meet project specific catchment hydraulics. The following information is required for the customisation of the vortex throttle:

- Required and/or specified maximum discharge volume
- Required build-up: pipe bottom drainage to top edge of water level
- Required diameter for the outlet pipe
- Required method and dimensions of the flow restriction shaft

Characteristics and benefits

- Controls the discharge of water into the receiving water or into the sewage system
- Equipped with a prescribed, maximum throttle discharge capacity
- Self-activating system
- Minimises the blockage risk
- Reduces maintenance requirements
- Maintenance free
- Designed and tested for throttle outputs of 1-100 l/s
- Fits into rectangular and round shafts
- Durable and corrosion resistant system
- Individually configured so that the system can fulfil specific project requirements

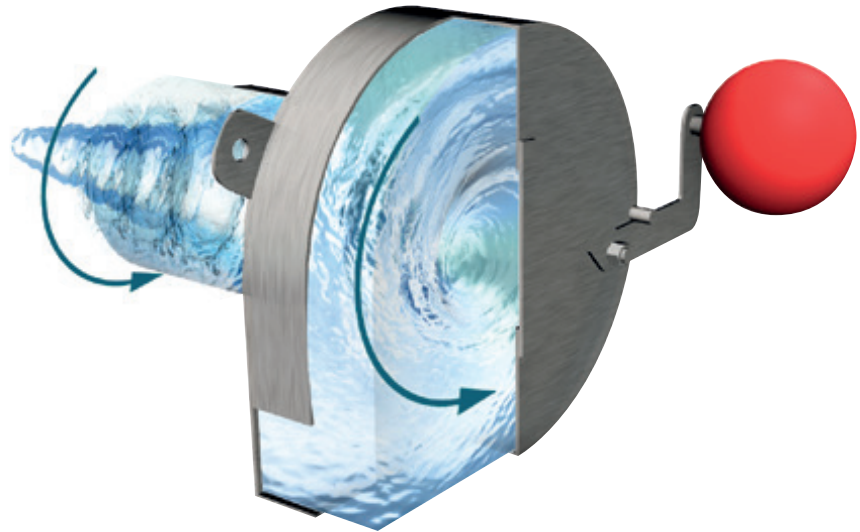

Typical use: block infiltration drain as retention with controlled discharge via the ACO Q-Brake vortex throttle

The Q-Brake vortex throttle and the ACO Stormbrixx retention block provide a fully integrated rainwater management system.

The ACO Q-Brake vortex throttle is therefore utilised for regulating the discharge from the retention basin into the receiving water or sewage system.

Optional protective non-woven fabric

Non-woven fabric filter or optional welded film

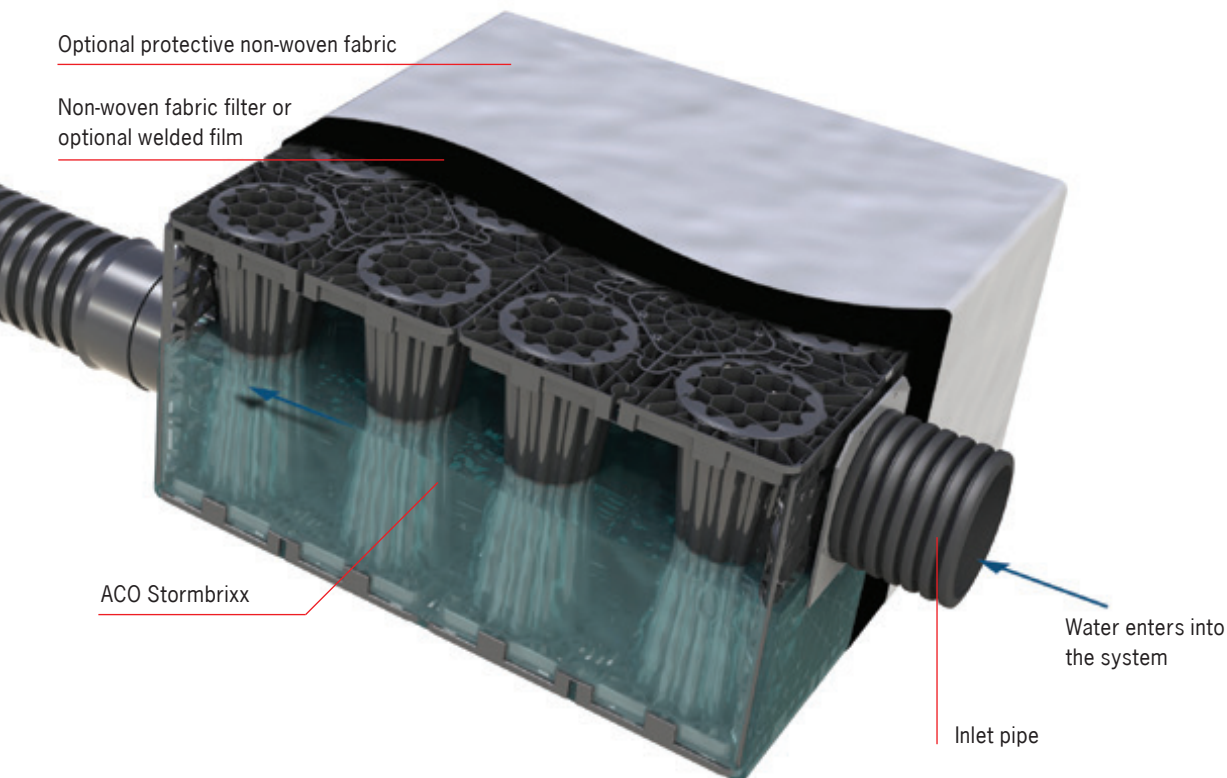

Overview of the characteristics of the ACO Q-Brake vortex throttle

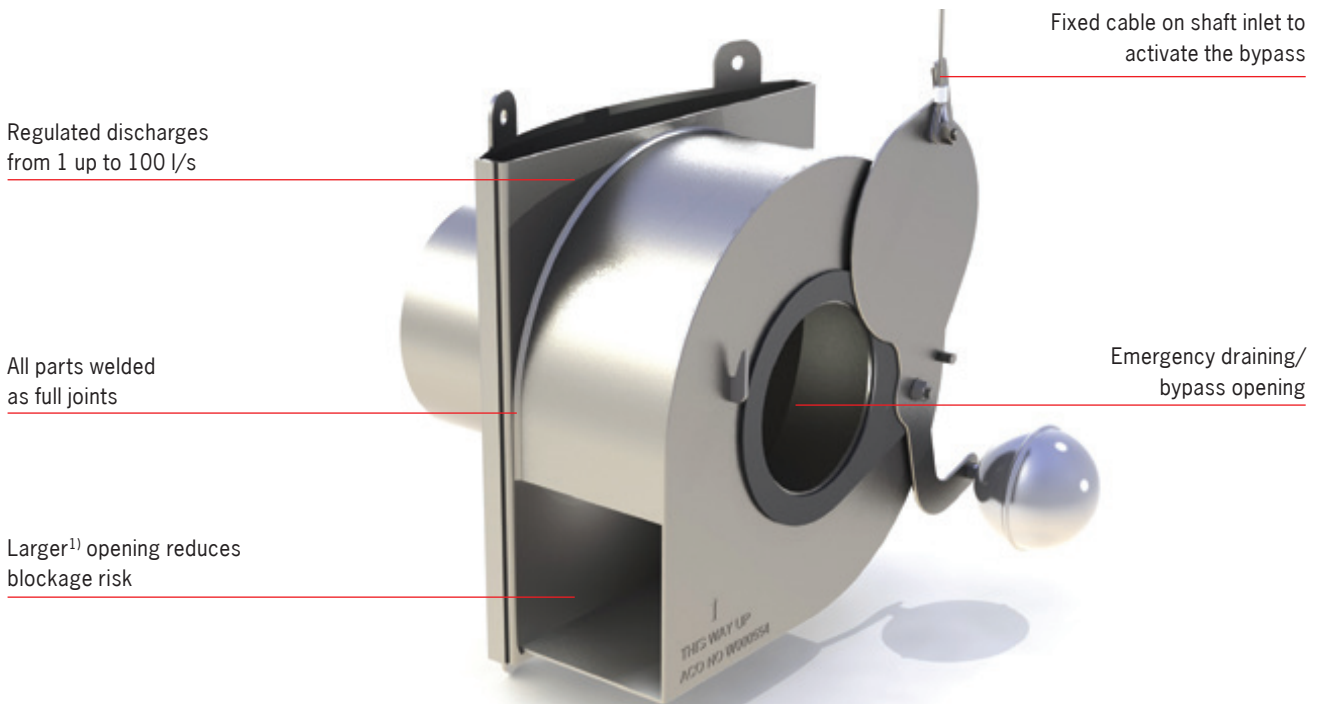
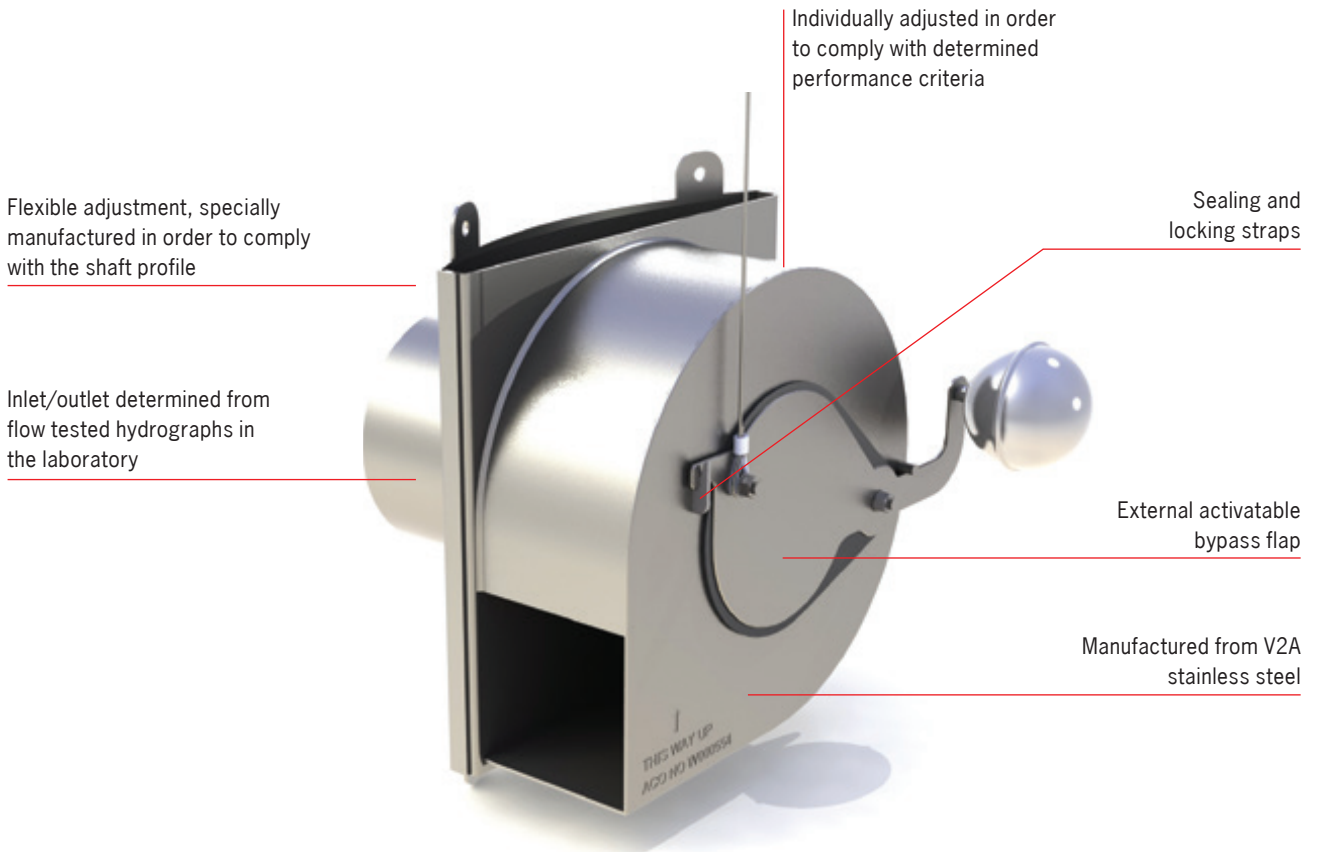

¹⁾ 4 - 6 times larger opening than customary throttle apertures

ACO Q-Brake vortex throttle design variants

The ACO Q-Brake vortex throttle is available for discharges between 1 to 100 l/s. Every Q-Brake is equipped as standard with a bypass sewer pipe for emergency draining. This is installed on the face side on the vortex throttle to enable a throttle discharge of 40 l/s.

The bypass sewer pipe is attached to the side of the vortex throttle (refer to following figures) should the throttle discharge exceed > 40 l/s. The ACO Q-Brake will either be installed in a concrete shaft provided by others or supplied assembled by ACO. This can be round or rectangular.

Shaft diameters up to a maximum of 3.0 m are possible in round shafts. The fastening kit comprising seal and bolts is delivered as standard with every Q-Brake.

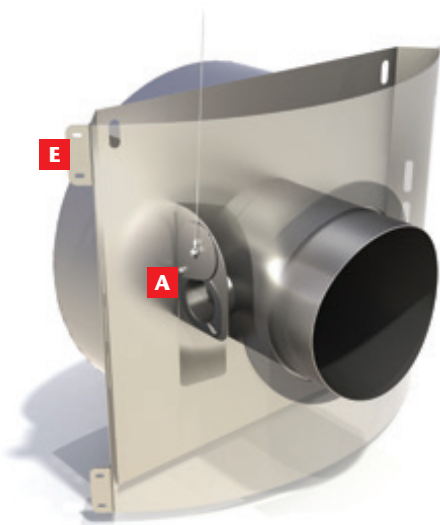

Design version for round shaft (rear side)

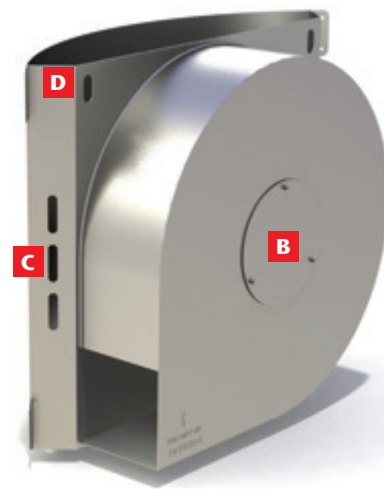

Design version for round shaft (front side)

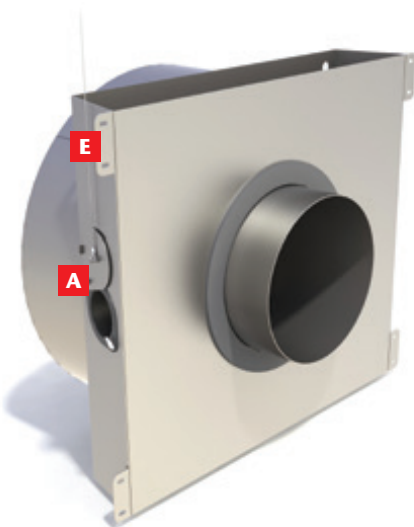

Design version for rectangular shaft (rear side)

- A** External activatable bypass door for emergency draining Arranged on the side for throttle discharges > 40 l/s.
- B** Removable inspection opening
- C** Side slots for facilitate drainage when assembling in round shafts
- D** Lifting eyes
- E** Fastening straps

Technical information

Surface water drainage

Civil engineering catalogue T 1

Brochure “ACO road gullies and top sections”

www.aco-tiefbau.de/produkte



Cleaning systems

Sedimentation systems

Heavy metal separators

Light liquid separators



Infiltration/attenuation systems

Stormbrixx SD

Page 70

Stormbrixx HD

Page 72

Control systems

Throttle shafts

Page 74

Further technical information:

Civil engineering catalog T 2

www.aco-tiefbau.de/produkte



Stormbrixx SD – Specifications of the construction elements

| Picture | Dimensional drawing | Dimension | | | Weight [kg] | Item number |
|---|---------------------|-------------|------------|-------------|-------------|---------------|
| | | Length [mm] | Width [mm] | Height [mm] | | |
| Basic element made of polypropylene (PP) | | | | | | |
| | | 1200 | 600 | 494 | 9.5 | 314090 |
| Side panel made of polypropylene (PP) | | | | | | |
| | | 907 | 592 | 104 | 3.1 | 314091 |
| Top cover made of polypropylene (PP) | | | | | | |
| | | 550 | 550 | 50 | 0.8 | 314092 |
| Cover plate for half layer | | | | | | |
| | | 1200 | 60 | 40 | 3.7 | 314094 |



Basic element double pallet



Top cover

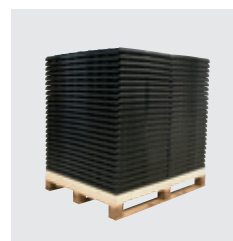

Side panel

Accessories

| Picture | Description | Suitable for | Weight [kg] | Item number |
|---|---|---|---|---|
|  | <p>Connector</p> <ul style="list-style-type: none"> ■ For connecting basic elements to each other □ For connecting two layers combining 2 connectors ■ Number of connectors when installing 2 layers: 1/2 the number of basic elements in the complete infiltration block ■ Number of connectors when installing 3 layers: 2/3 the number of basic elements in the complete infiltration block ■ Made of polypropylene (PP) | <ul style="list-style-type: none"> ■ ACO Stormbrixx basic element | 0.1 | 314093 |
| |  <p>Adapter for pipe connection</p> <ul style="list-style-type: none"> ■ Made of polyethylene (PE) | <ul style="list-style-type: none"> ■ ACO Stormbrixx basic element | <ul style="list-style-type: none"> DN/OD 110 DN/OD 160 DN/OD 200 DN/OD 250 DN/OD 315 | <ul style="list-style-type: none"> 0.4 0.7 1.3 2.7 3.3 |
|  | <p>Inspection and rinsing shaft</p> <ul style="list-style-type: none"> ■ As inspection and rinsing access to the infiltration system ■ With formwork support ■ Made of polypropylene (PP) | <ul style="list-style-type: none"> ■ ACO Stormbrixx basic element | 2.6 | 314038 |
|  | <p>Inspection and rinsing shaft with socket</p> <ul style="list-style-type: none"> ■ As inspection and rinsing access to the infiltration system ■ DN/OD 160 ■ With formwork support ■ Made of polypropylene (PP) | <ul style="list-style-type: none"> ■ ACO Stormbrixx basic element | 2.8 | 314039 |
|  | <p>Access plate</p> <ul style="list-style-type: none"> ■ Access within the system ■ Easy installation at any desired position ■ Dimensions: 650 x 650 x 120 mm ■ Made of polypropylene (PP) | <ul style="list-style-type: none"> ■ Anschluss nach oben DN/OD 400 | 5,5 | 314075 |
|  | <p>Manhole cover SA 400</p> <ul style="list-style-type: none"> ■ Load class D 400 ■ Made of EN-GJS cast iron ■ Clear width 400 ■ No air vents | <ul style="list-style-type: none"> ■ Inspection and rinsing shaft | 38.0 | 314043 |
|  | <p>Manhole cover SA 400</p> <ul style="list-style-type: none"> ■ Load class D 400 ■ Made of EN-GJS cast iron ■ Clear width 400 ■ With air vents | <ul style="list-style-type: none"> ■ Inspection and rinsing shaft | 38.0 | 314053 |
|  | <p>Manhole cover SA 160</p> <ul style="list-style-type: none"> ■ Access for inspection ■ Load class D 400 ■ Made of EN-GJL cast iron ■ Clear width 160 ■ No air vents | <ul style="list-style-type: none"> ■ Connectors DN/OD 160 | 15.7 | 314044 |

Stormbrixx HD – Specifications of the construction elements

| Picture | Dimensional drawing | Dimension | | | Weight [kg] | Item number |
|---|---------------------|----------------|---------------|----------------|----------------|----------------|
| | | Length [mm] | Width [mm] | Height [mm] | | |
| Basic element made of polypropylene (PP) | | | | | | |
| | | 1205 | 602 | 343 | 10.0 | 314061 |
| Side panel made of polypropylene (PP) | | | | | | |
| | | 600 | 600 | 55 | 1.6 | 314062 |
| Top cover made of polypropylene (PP) | | | | | | |
| | | 548 | 548 | 43 | 0.8 | 314022 |



Basic element double pallet



Top cover



Side panel

Accessories

| Picture | Description | Suitable for | Weight [kg] | Item number |
|---|---|---|--|--|
|  | <p>Connector</p> <ul style="list-style-type: none"> ■ For connecting basic elements to each other <ul style="list-style-type: none"> □ For connecting two layers combining 2 connectors ■ Number of connectors when installing 2 layers: 1/2 the number of basic elements in the complete infiltration block ■ Number of connectors when installing 3 layers: 2/3 the number of basic elements in the complete infiltration block ■ Made of polypropylene (PP) | <ul style="list-style-type: none"> ■ ACO Stormbrixx basic element | 0.1 | 314023 |
| | <p>Adapter for pipe connection</p> <ul style="list-style-type: none"> ■ Made of polyethylene (PE) | <ul style="list-style-type: none"> ■ ACO Stormbrixx basic element | <ul style="list-style-type: none"> DN/OD 110 DN/OD 160 DN/OD 200 DN/OD 250 DN/OD 315 DN/OD 400 | <ul style="list-style-type: none"> 0.4 0.7 1.3 2.7 3.3 4.5 |
|  | <p>Inspection and rinsing shaft</p> <ul style="list-style-type: none"> ■ As inspection and rinsing access to the infiltration system ■ With formwork support ■ Made of polypropylene (PP) | <ul style="list-style-type: none"> ■ ACO Stormbrixx basic element | 2.6 | 314038 |
|  | <p>Inspection and rinsing shaft with socket</p> <ul style="list-style-type: none"> ■ As inspection and rinsing access to the infiltration system ■ DN/OD 160 ■ With formwork support ■ Made of polypropylene (PP) | <ul style="list-style-type: none"> ■ ACO Stormbrixx basic element | 2.8 | 314039 |
|  | <p>Access chamber</p> <ul style="list-style-type: none"> ■ As access to infiltration system ■ For connecting inlets and outlets within the infiltration system ■ Dimensions: 594 x 594 x 610 mm ■ Made of polyethylene (PE) | <ul style="list-style-type: none"> ■ Connectors up to DN/OD 400 | 32.0 | 27034 |
|  | <p>Access plate</p> <ul style="list-style-type: none"> ■ Access within the system ■ Easy installation at any desired position ■ Dimensions: 650 x 650 x 120 mm ■ Made of polypropylene (PP) | <ul style="list-style-type: none"> ■ Anschluss nach oben DN/OD 400 | 5,5 | 314083 |
|  | <p>Manhole cover SA 400</p> <ul style="list-style-type: none"> ■ Load class D 400 ■ Made of EN-GJS cast iron ■ Clear width 400 ■ No air vents | <ul style="list-style-type: none"> ■ Inspection and rinsing shaft | 38.0 | 314043 |
|  | <p>Manhole cover SA 400</p> <ul style="list-style-type: none"> ■ Load class D 400 ■ Made of EN-GJS cast iron ■ Clear width 400 ■ With air vents | <ul style="list-style-type: none"> ■ Inspection and rinsing shaft | 38.0 | 314053 |
|  | <p>Manhole cover SA 160</p> <ul style="list-style-type: none"> ■ Access for inspection ■ Load class D 400 ■ Made of EN-GJL cast iron ■ Clear width 160 ■ No air vents | <ul style="list-style-type: none"> ■ Connectors DN/OD 160 | 15.7 | 314044 |

Throttle shafts

ACO product advantages

- Space-saving shallow flow restrictor valve
- Corrosion resistant stainless steel construction made of material grade 304
- Division scale for adjustment and indication of the valve plate opening height
- Telescopic spindle extension with square drive and spindle holder

- 1 x installation material required (Art. No. 702816) for each spindle extension
- Note: Flow restriction shafts are designed individually. Contact us. Tel. 0049 (0) 6206 9816-0, tiefbau@aco.com

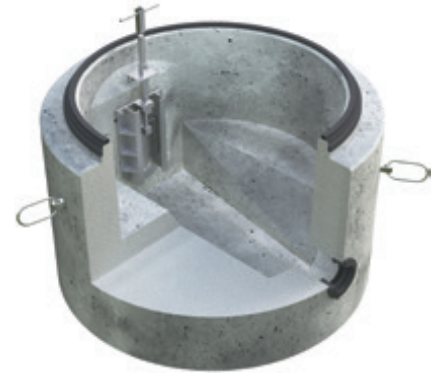

| Type | Q _{Dr} [l/s] | Inlet/ Outlet DN/OD [mm] | Weight of basin [kg] | Top assembly 1 Article No. | Article No. |
|--------|--------------------------|-----------------------------------|-------------------------|-------------------------------|---------------|
| 2-10 | 2-10 | 110 | 1655 | 728061 | 725150 |
| 10-48 | 10-48 | 200 | 1644 | 728061 | 725152 |
| 35-128 | 35-125 | 315 | 1619 | 728061 | 725154 |
| 80-256 | 80-256 | 400 | 2100 | 728062 | 725156 |

Spindle extension

| Designation | Article No. | Weight [kg] | Flow restriction shaft DN/OD 110 Art. No. 725150 | | | Flow restriction shaft DN/OD 200 Art. No. 725152 | | |
|-------------|-------------|----------------|---|-----------------------|-----------------------|---|-----------------------|-----------------------|
| | | | Inlet depths of the flow restriction shaft | | | | | |
| | | | Spindle extension | | | Spindle extension | | |
| | | | without T = Standard [mm] | with T min [mm] | with T max [mm] | without T = Standard [mm] | with T min [mm] | with T max [mm] |
| 1500-2600 | 717980 | 4.5 | 910 | 1015 | 3200 | 930 | 1065 | 3400 |
| 2600-5500 | 717981 | 8.3 | 910 | 3200 | 6100 | 930 | 3400 | 6305 |

| Designation | Article No. | Weight [kg] | Flow restriction shaft DN/OD 315 Art. No. 725154 | | | Flow restriction shaft DN/OD 400 Art. No. 725156 ²⁾ | | |
|-------------|-------------|----------------|---|---------------|-----------------------|---|---------------|-----------------------|
| | | | Inlet depths of the flow restriction shaft | | | | | |
| | | | Spindle extension | | | Spindle extension | | |
| | | | without T = Standard [mm] | T min [mm] | with T max [mm] | without T = Standard [mm] | T min [mm] | with T max [mm] |
| 1500-2600 | 717980 | 4.5 | 1225 ¹⁾ | 1230 | 3600 | 1495 ¹⁾ | 1610 | 3800 |
| 2600-5500 | 717981 | 8.3 | 1225 ¹⁾ | 3600 | 6500 | 1495 ¹⁾ | 3800 | 6700 |

¹⁾ At least 1x shaft ring 250 mm high (Art. 728110) or higher required

²⁾ If size 800 supporting rings are required: use only Art. No. 727468 (AR-V 800 * 80 Type II) and/or 727469 (AR-V 800 * 100 Type II)

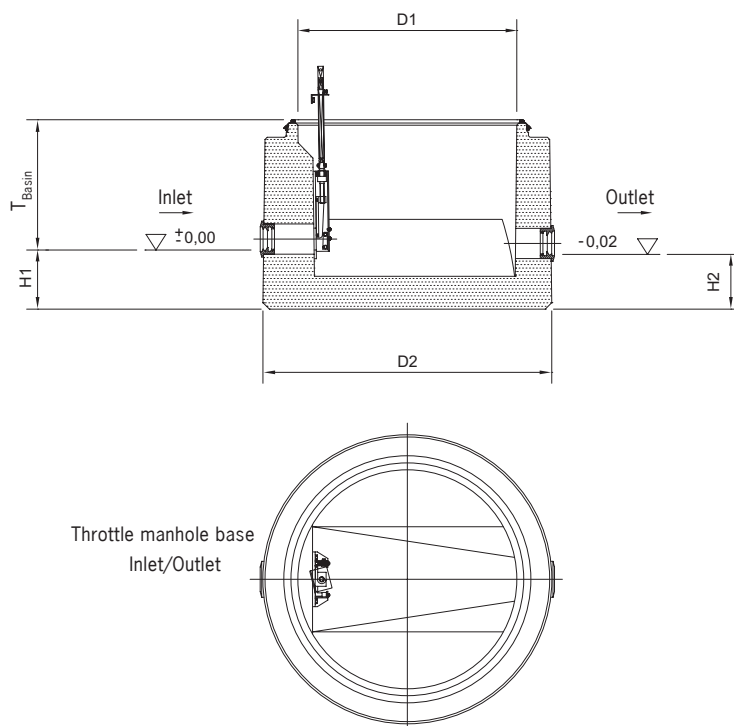

| Type | Article No. | Dimension | | | | | T_{Basin} [mm] | T_{max} ¹⁾ [mm] |
|--------|---------------|---------------|---------------|---------------|---------------|----------------------------|----------------------------|--|
| | | H_1 [mm] | H_2 [mm] | D_1 [mm] | D_2 [mm] | T_{Basin} [mm] | | |
| 2-10 | 725150 | 270 | 250 | 1000 | 1320 | 595 | 3000 | |
| 10-48 | 725152 | 225 | 205 | 1000 | 1320 | 640 | 3000 | |
| 35-128 | 725154 | 220 | 200 | 1000 | 1320 | 645 | 3000 | |
| 80-256 | 725156 | 270 | 250 | 1200 | 1500 | 895 | 3000 | |

¹⁾ Larger installation depths on request.

ACO materials

In the design of components and structural elements, the choice of suitable material determines the aesthetic and functional qualities of the product. The materials used by ACO are characterised by their strength, ageing resistance and their resistance to aggressive media, frost, heat and sunlight. Thanks to their long life and recyclability, they are equally sustainable and environmentally compatible and are used in an application-orientated way.

Polymer concrete

With 30 production locations worldwide, we consistently implement our ideas of product quality, economic efficiency and on-time delivery to our customers. Each of our factories has special materials expertise, from which the entire ACO Group profits. Keeping our production technology and ecological performance up-to-date and in line with the latest standards is part of our standard of acting responsibly as a company and to be a worldwide leader.



ACO polymer concrete – a better idea

The special material composition and state-of-the-art production technology give polymer concrete its outstanding properties profile. ACO polymer concrete products have high strength values and a low weight. ACO polymer concrete is waterproof. Water dries quickly. Frost damage is excluded. The smooth surface of ACO polymer concrete allows water and dirt particles to run off quickly and is easy to clean. Polymer concrete is also resistant to aggressive media without requiring additional coatings and can be used versatily and durably even under extreme conditions.

Cast iron



ACO cast iron – quality for all standards

The types of cast iron used by ACO Guss in Kaiserslautern and Aarbergen are adapted to the continuously increasing requirements through intensive innovation and development processes: Both cast iron with lamellar graphite (grey cast iron GJL) and cast iron with nodular graphite (spheroidal cast iron GJS) have proven their worth as materials for use in cast iron sewers due to their high corrosion resistance. ACO Guss offers the optimum solution for the respective application, independent of the material.

Plastic



ACO plastic – innovative and flexible

Components made of plastic offer the greatest possible design freedom with regard to form and function. We use this potential to avoid expensive material combinations and time-consuming jointing processes and to develop intelligent solutions “cast in one piece” to take their place. The plastics used by ACO are characterised not only by their high breaking stress (crushing strength) but also by their outstanding resistance to environmental influences. Simple machining options and low weight are the reasons for the outstanding user-friendliness of our plastic solutions.

Steel/stainless



ACO steel/stainless steel – sophisticated components

The processing of both steel and stainless steel is a core expertise of ACO in the different production facilities of the ACO Group worldwide. Large investment sums ensure that our production facilities are always state-of-the-art. The high qualification of our skilled workers ensure high-quality products. Our own in-house plants for surface protection and finishing are used, among other things, in the production of ACO Drainlock gratings.

Concrete



ACO concrete – durable and reliable

Concrete is a material that plays a decisive role in tank construction for separator and drainage technology. ACO tanks for drainage technology are made from a highly waterproof concrete, have a very high resistance and stability. The tanks can be used as separators, pumping stations, accident (spillage) systems or special chambers and can also be equipped with a plastic coating or lining. ACO tanks made of concrete are a durable solution for the drainage and treatment of water.

The ACO offer for customers

Every project is different, with its own demands and challenges.

In addition to our top products, we also make available our in-depth know-how and our services to assist you in developing individual customised solutions – from planning to service provision after completion.



train:

Information and further training

At the ACO Academy, we share the in-depth expertise of the global ACO Group with architects, planners, operatives and dealers who place a high priority on quality. We invite you to attend and benefit from this know-how.

design:

Planning and optimisation

Tendering and planning for drainage solutions can be based on a range of possible options. But which concept produces the best economic and safest technical solution? We can help you find the optimum answer.



support:

Construction advice and assistance

To ensure that there are no nasty surprises between the planning and implementation of a drainage solution, we can provide you with project specific advice and support at your construction site.

care:

Inspection and maintenance

ACO products are designed and manufactured for long service lives. With our after sales service, we ensure that ACO fully satisfies its high quality standards even after many years of efficient operation.

www.aco-tiefbau.de

ACO Tiefbau on the internet

You will find our products with all the information important to you on the ACO Tiefbau website. You can use it during the design, not only to access technical descriptions but also the corresponding image information and tender specification texts and installation instructions and information.

ACO academy for practical training

The ACO Academy events are something special: They impart sound practical knowledge of all aspects of construction and at the same time, are a place for practitioners from the entire industry to meet and exchange ideas and experiences. The ACO academy is a forum for excellent building. Future topics of the construction industry and compact know-how for all aspects of construction are taught with practical reference. Find out about the contents of the seminars on offer.

Do you have any further questions? askACO

We invite you to askACO. Together, we can find the right solution for your specific drainage problem.

www.aco-tiefbau.de/askaco





**ACO Severin Ahlmann
GmbH & Co. KG**

P. O. Box 320
24755 Rendsburg
Germany
Am Ahlmannkai
24782 Büdelsdorf
Germany
Phone +49 4331 354-0
Fax +49 4331 354-223
info@aco-international.com
www.aco.com